

Robotist

Chodiaci robot

Návod na stavbu









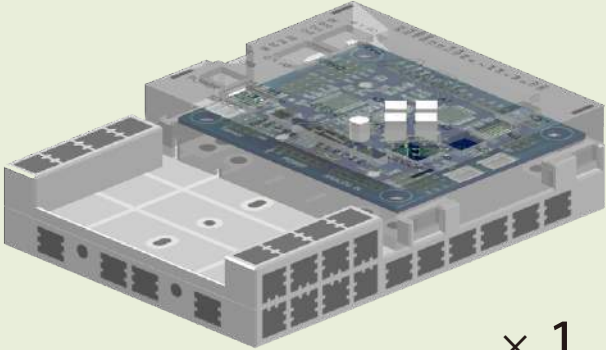
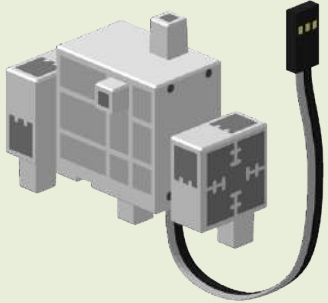
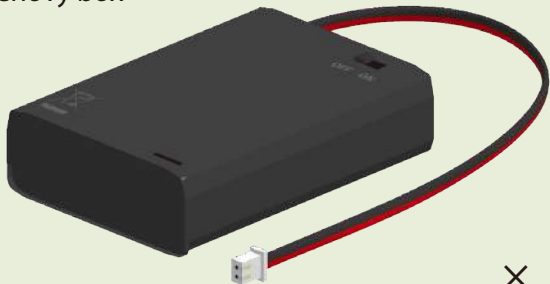
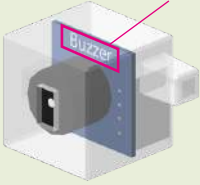
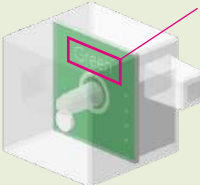
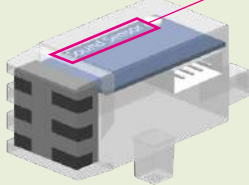
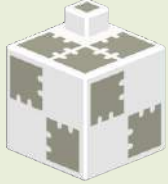
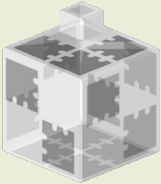
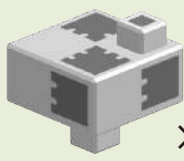

Artec PAT.P

Distribútor pre Slovensko:
Kvant spol. s r.o.
FMFI UK Mlynská dolina
842 48 Bratislava
Slovakia, Europe
E-mail: obchod@kvant.sk
web: www.kvant.sk

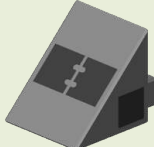
Chodiaci robot

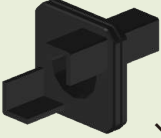
Komponenty

<p>Studuino základná doska</p>  <p>× 1</p>	<p>Servomotor</p>  <p>× 8</p>		
		<p>Batériový box</p>  <p>× 1</p>	
<p>Bzučiak</p>  <p>× 1</p>	<p>LED (zelená)</p>  <p>× 1</p>	<p>Zvukový senzor</p>  <p>× 1</p>	
<p>Základná kocka (biela)</p>  <p>× 19</p>	<p>Základná kocka (transparentná)</p>  <p>× 2</p>	<p>Polovičná A (svetlo šedá)</p>  <p>× 11</p>	
<p>Polovičná B (modrá)</p>  <p>× 11</p>	<p>Polovičná C (svetlá aqua)</p>  <p>× 38</p>	<p>Polovičná D (aqua)</p>  <p>× 14</p>	<p>Trojuholník A (šedá)</p>  <p>× 8</p>
<p>Trojuholník A (transparentná)</p>  <p>× 2</p>	<p>Os rotora C</p>  <p>× 2</p>	<p>USB kábel</p>  <p>× 1</p>	<p>Kábel pre senzor (Troj-žilový 15 cm)</p>  <p>× 3</p>

Chodiaci robot

Stavebný návod - označenia

D11

Nálepka s číslom servomotora.
Uistite sa že používate
servomotor so správnym
číslom.

× 1

Počet kusov jednotlivých
dielov potrebných ku stavbe.



Označuje varovania a typy
pri stavbe konkrétnej časti
stavebnice.



Indikuje zmenu smeru
komponentov pri
stavbe.

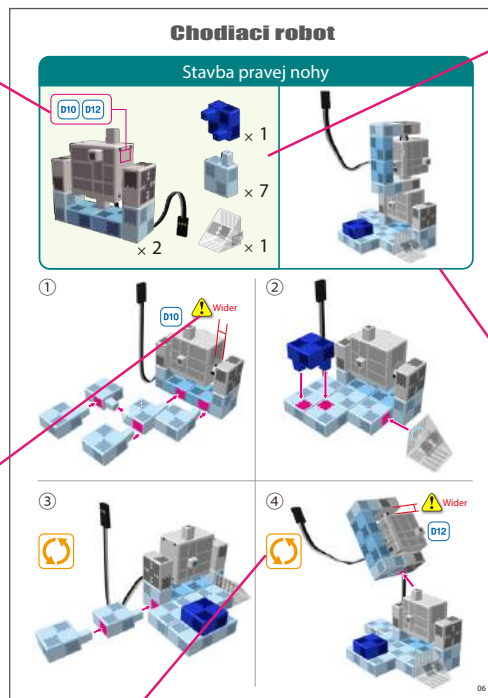

Zobrazuje obrázok
kompletne zloženej
časti stavebnice.

Chodiaci robot

Manipulácia so servomotorom

1 Orientácia

Foto vpravo ukazuje servomotor.
K dispozícii sú dva hriadele, jedna s širšou medzerou je hnacia hriadeľ a jedna s užšou medzerou je pohyblivý hriadeľ.

Ak otáčate osou hnacej hriadele rukou, robte to veľmi opatrne a pomaly. Nadmerný tlak pri otáčaní môže spôsobiť poškodenie servomotoru.

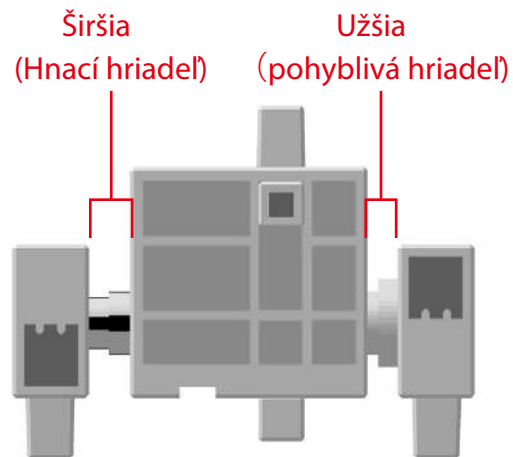

2 Kalibrácia a nastavenie čísla konektorov

Pred stavbou Vášho robota si prečítajte časť 6. Použitie servomotorov v programe Studuino Ikonové programovanie /sprievodca použitím/, ktorý je na stiahnutie na stránke: <http://www.artec-kk.co.jp/robotist/>

Stavbou robota bez kalibrácie servomotorov môžete spôsobiť poškodenie servomotorov alebo ich nesprávnu funkciu.

Nevymieňajte konektory alebo servomotory po pripojení.
Kalibrácia je unikátna pre každý konkrétny servomotor.

Označenie servomotorov nálepkami

Po kalibrácii servomotorov Vám odporúčame ich označenie nálepkami, čo umožní ich jednoduchú identifikáciu počas stavby.

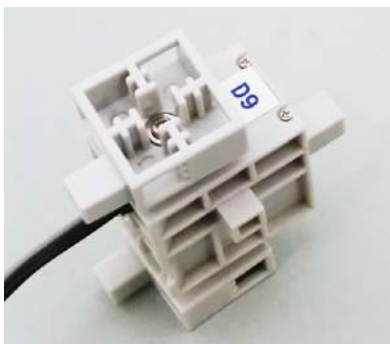

Chodiaci robot

Stavba Servomotora

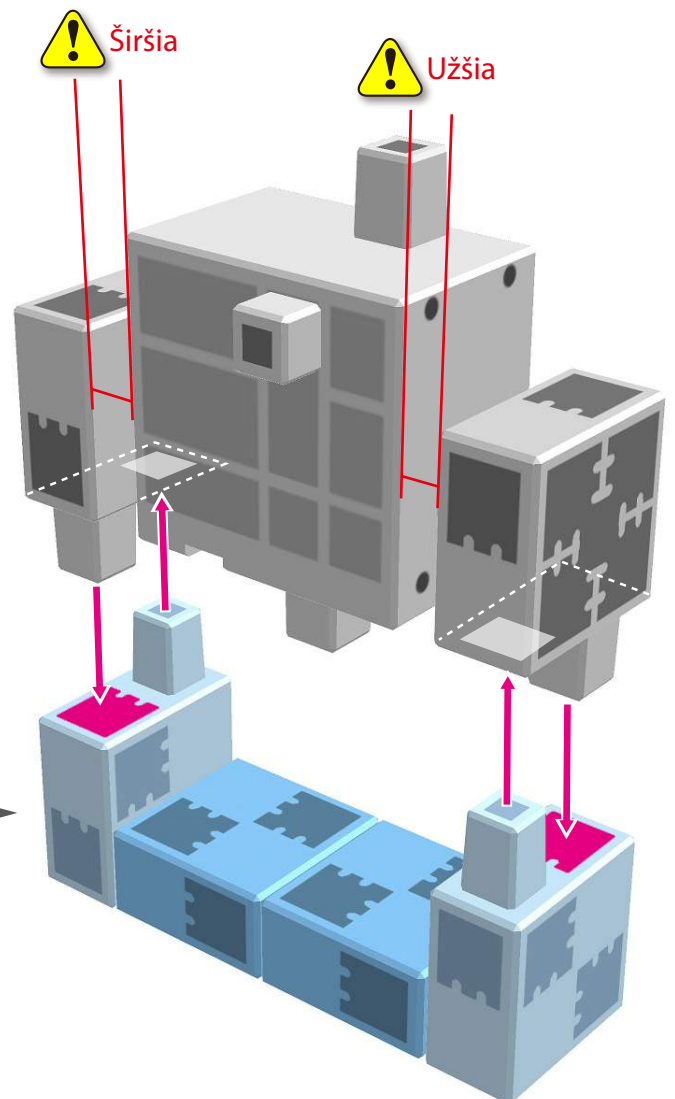
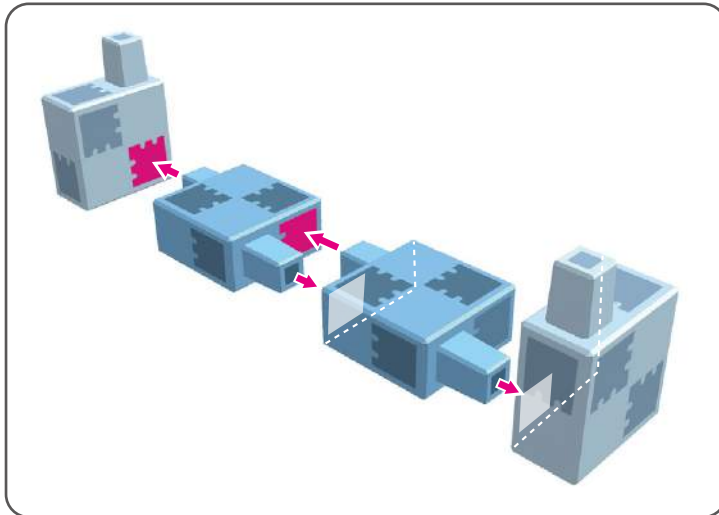
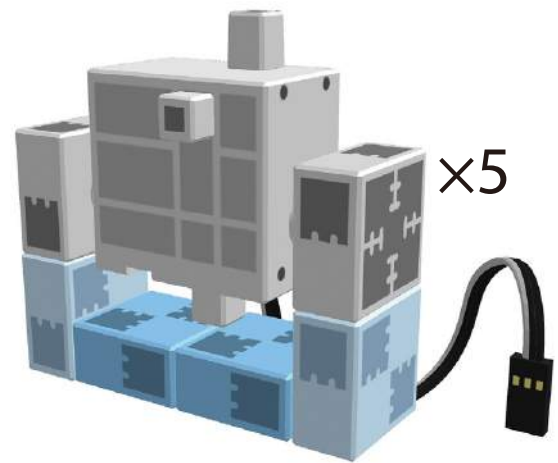
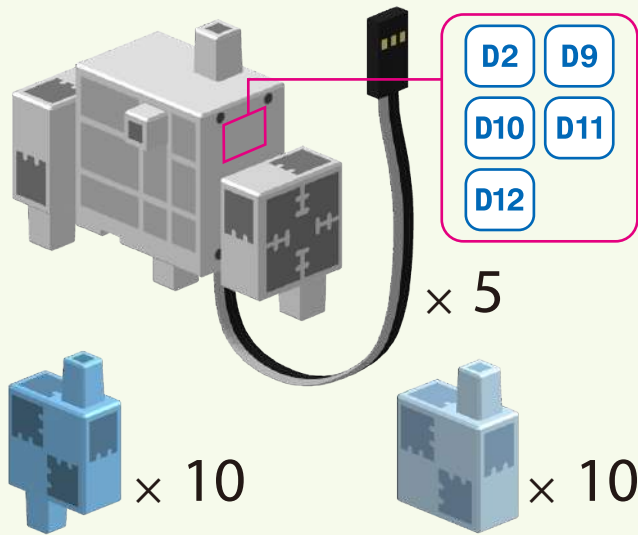

 Postavte celkom päťkrát.

Chodiaci robot

Stavba pravej nohy

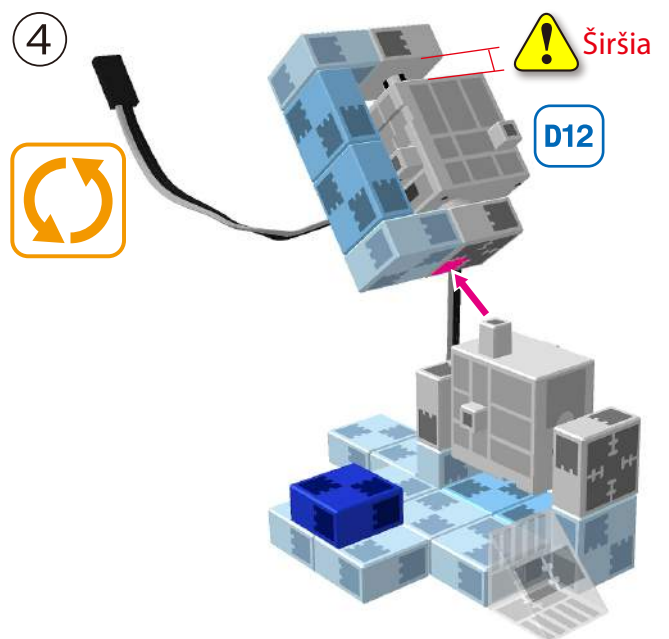
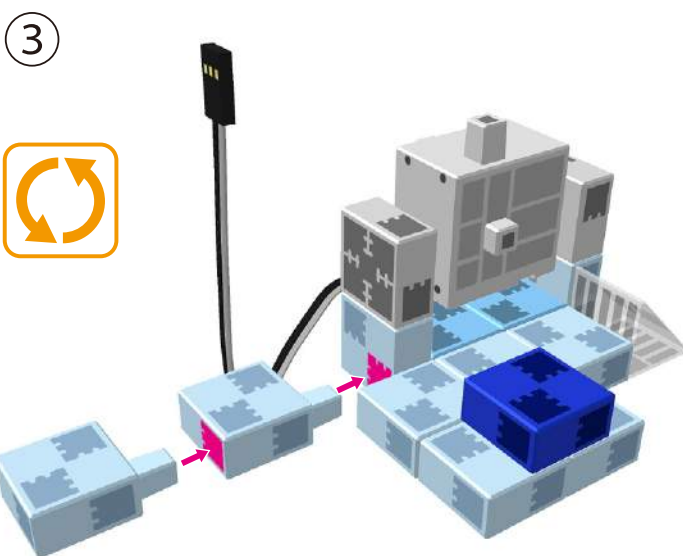
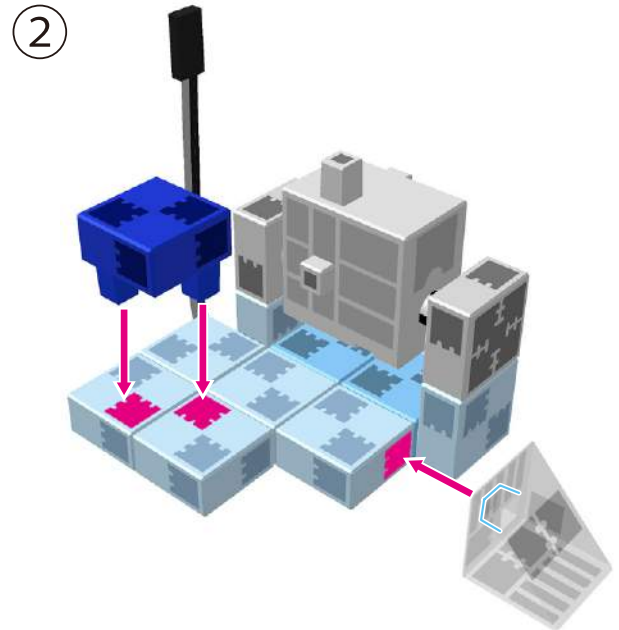
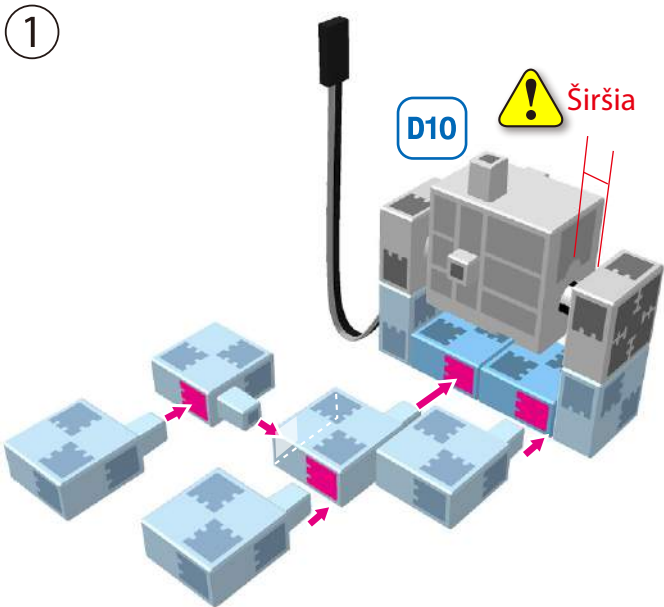
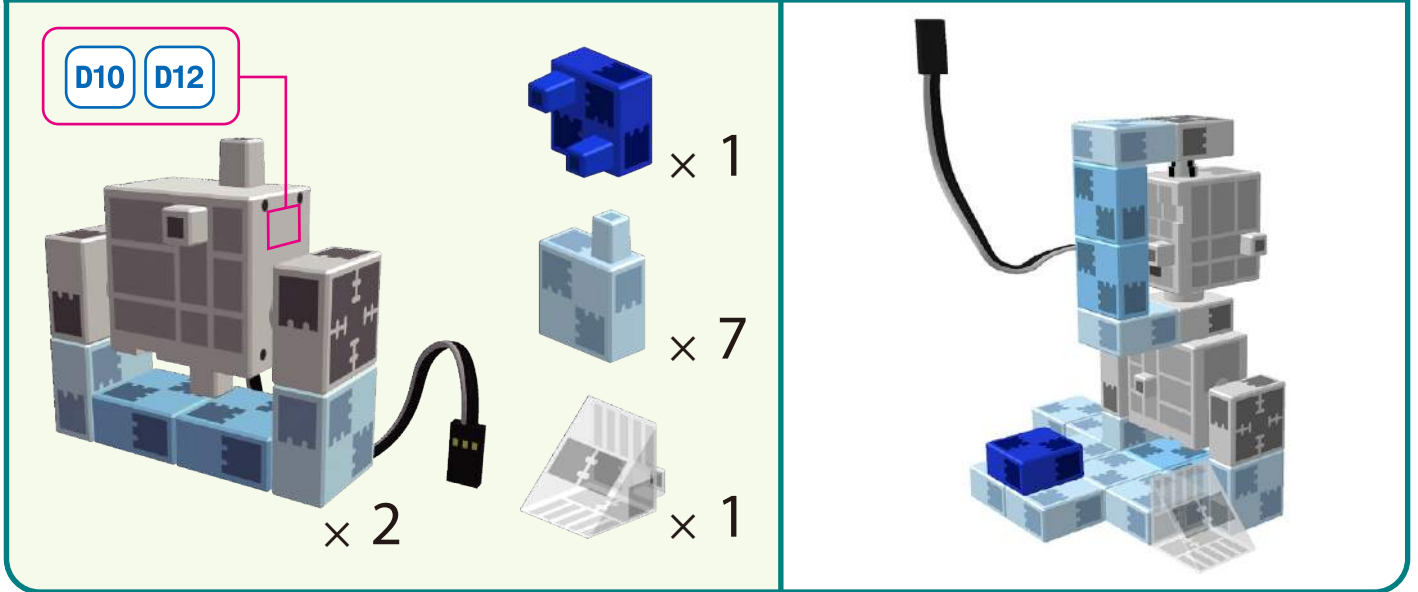

Chodiaci robot

Stavba lavej nohy

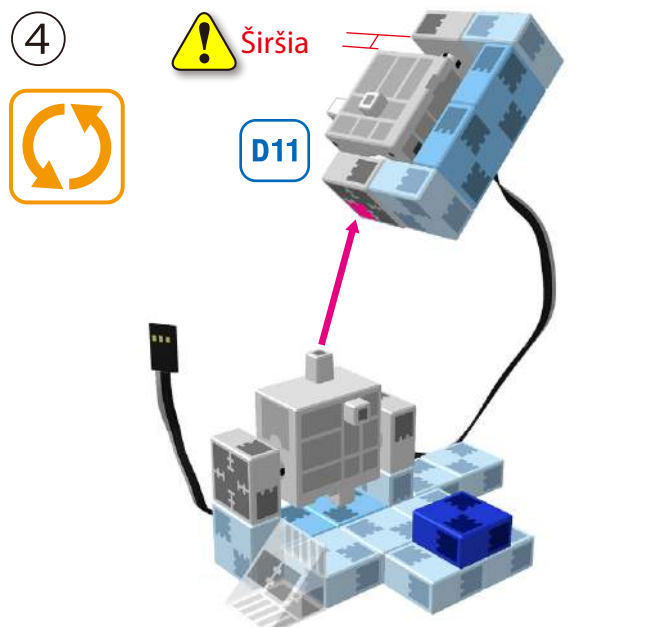
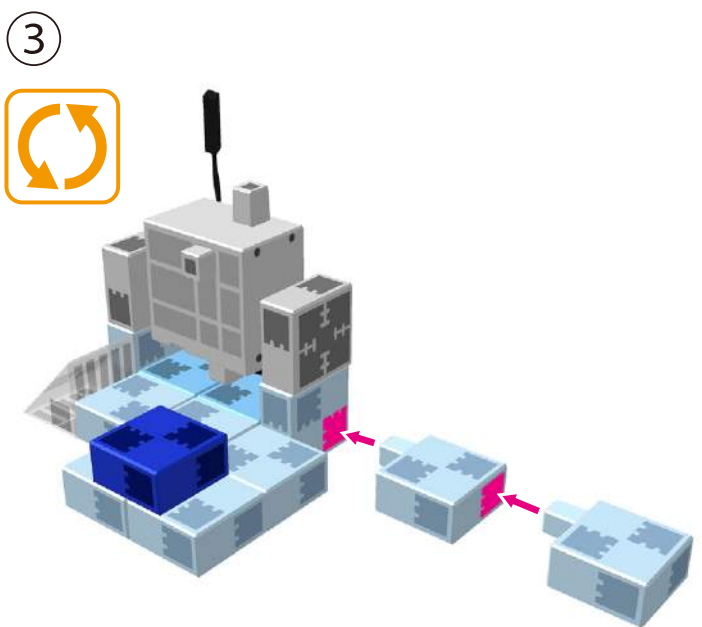
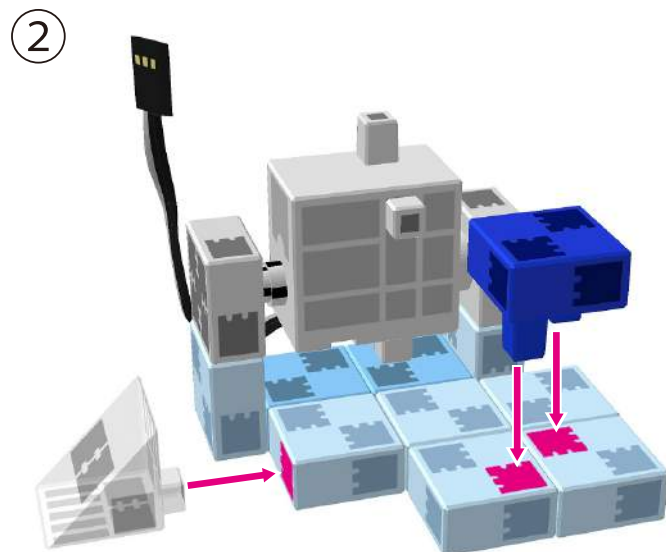
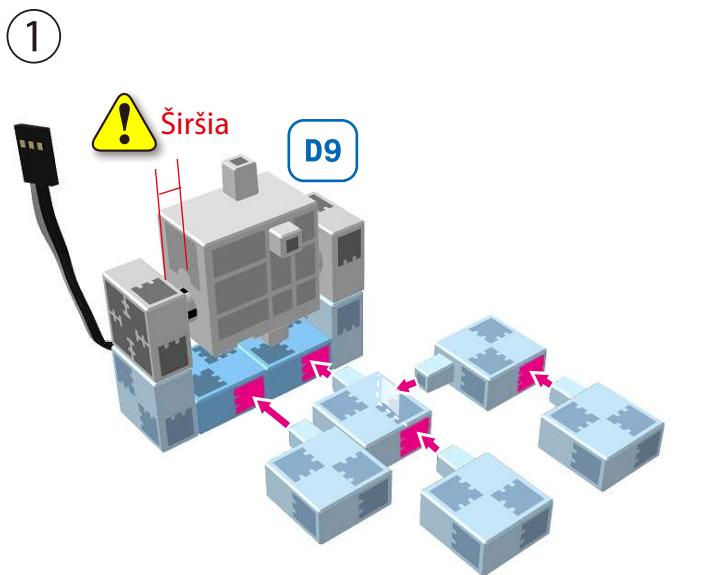
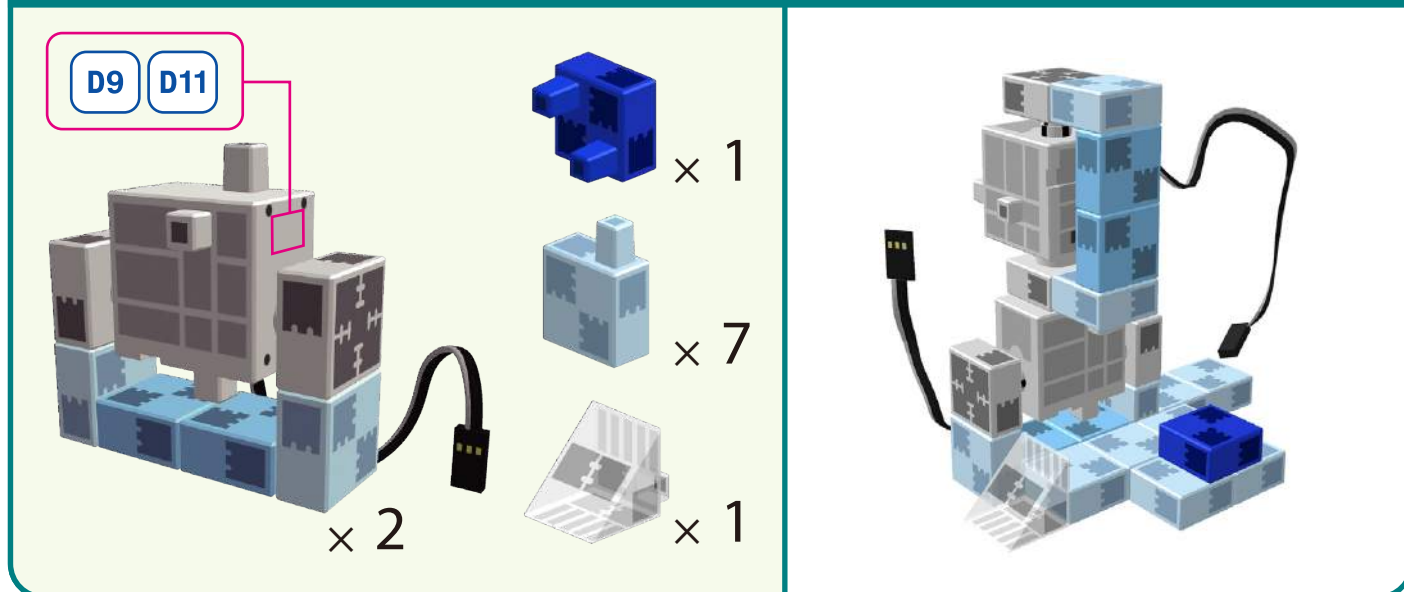

Chodiaci robot

Stavba spodnej polovice

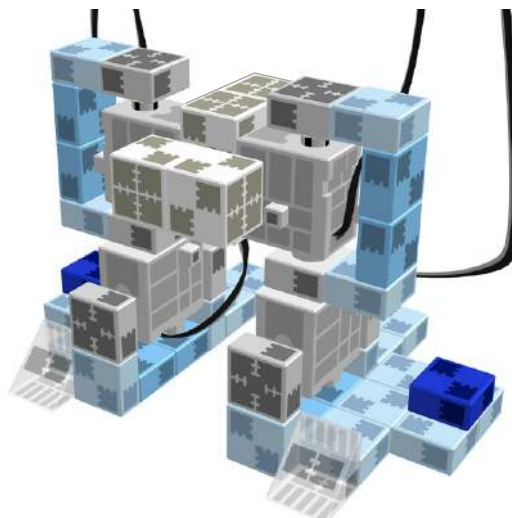
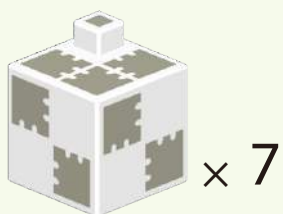

①

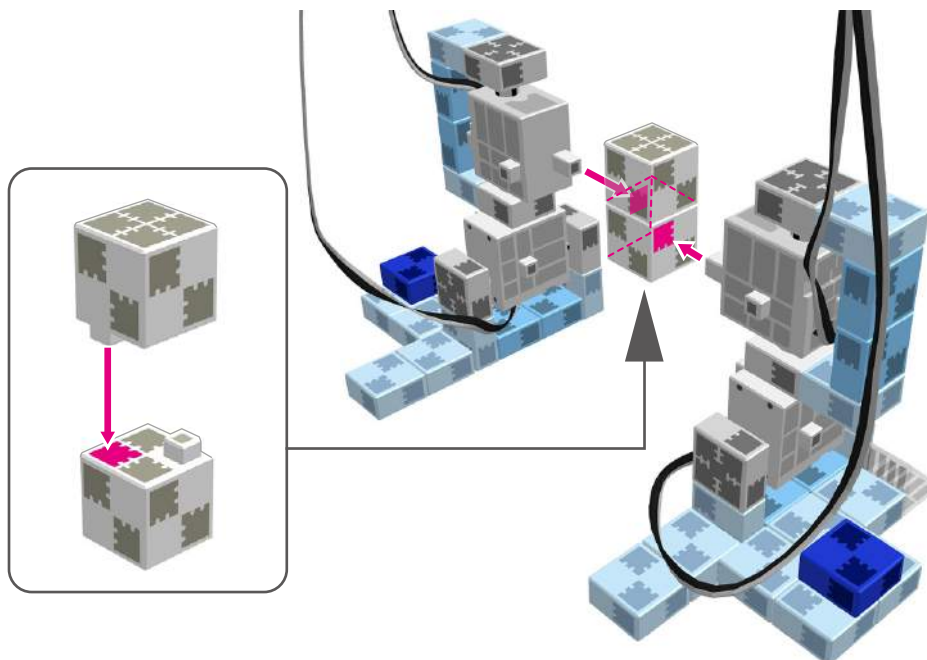

②

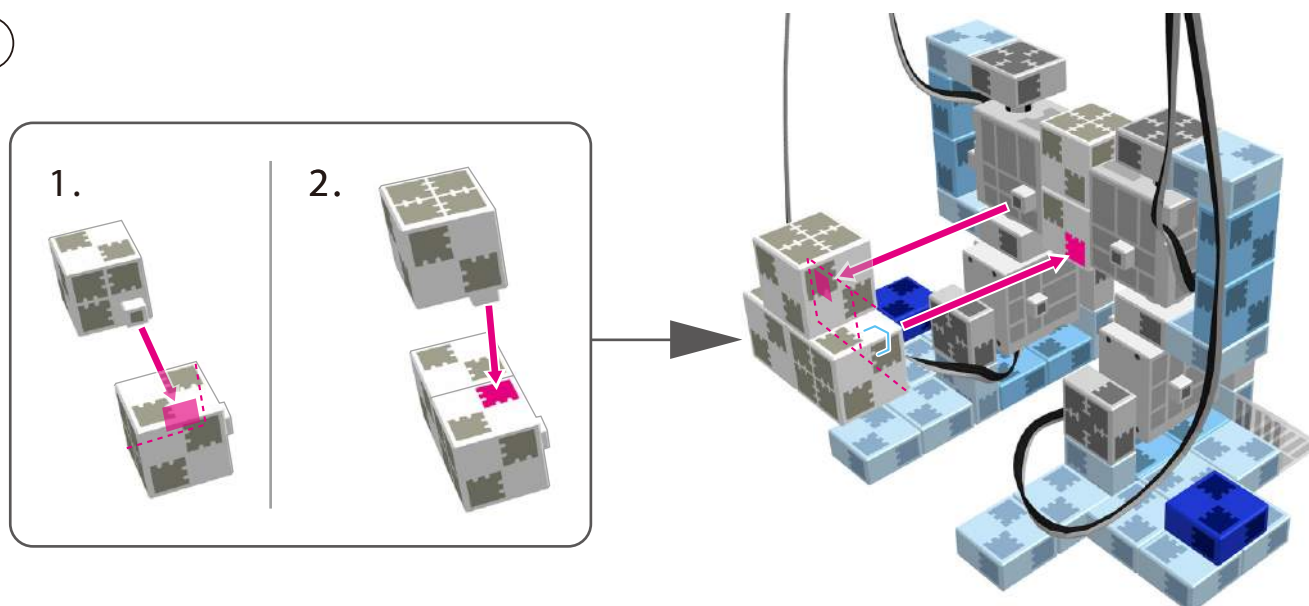

Chodiaci robot

3

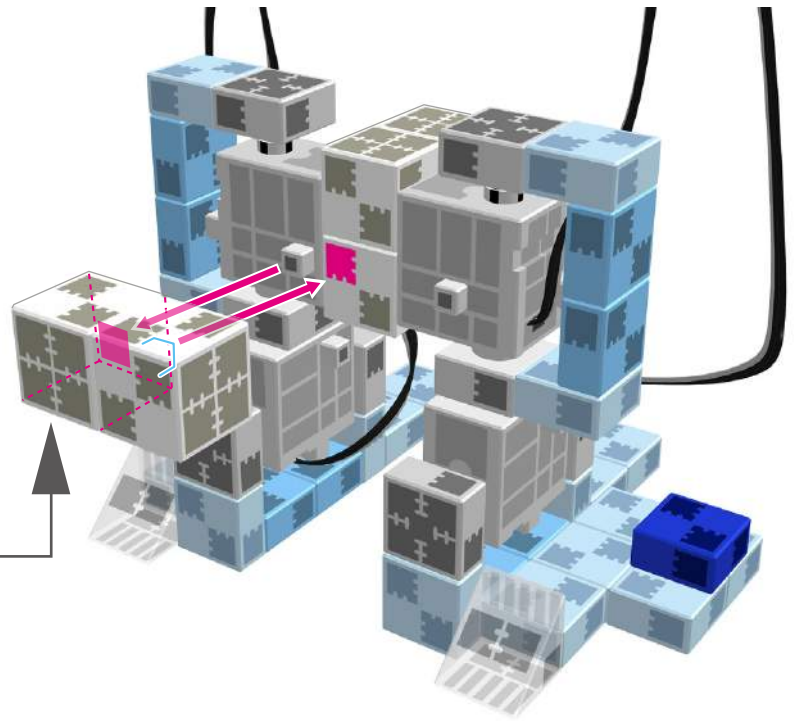
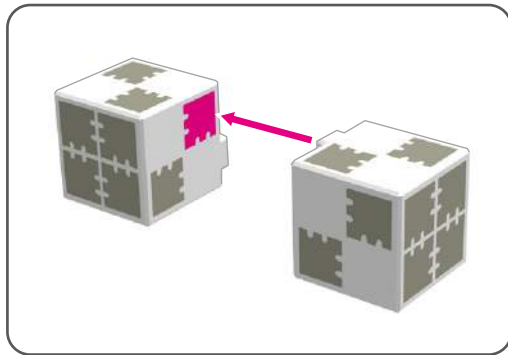

Dokončená spodná polovica

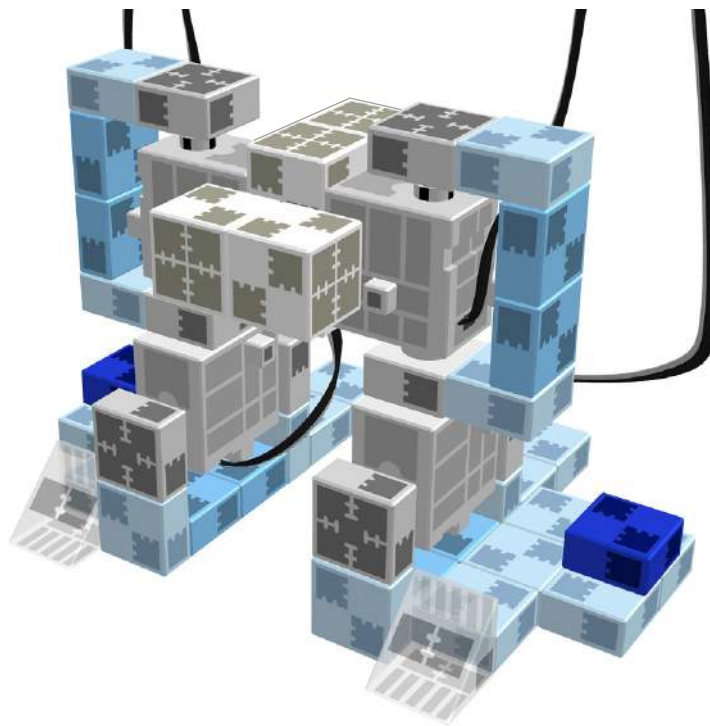

Chodiaci robot

Stavba - torzo

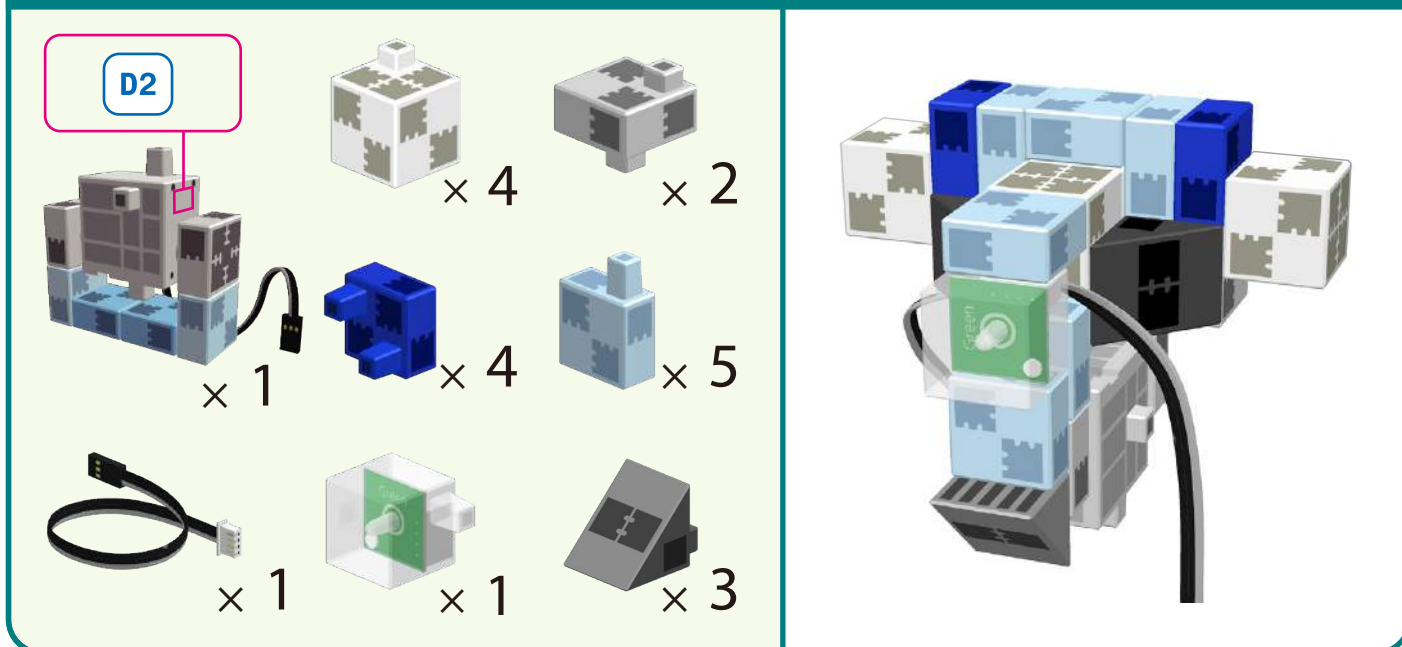

①

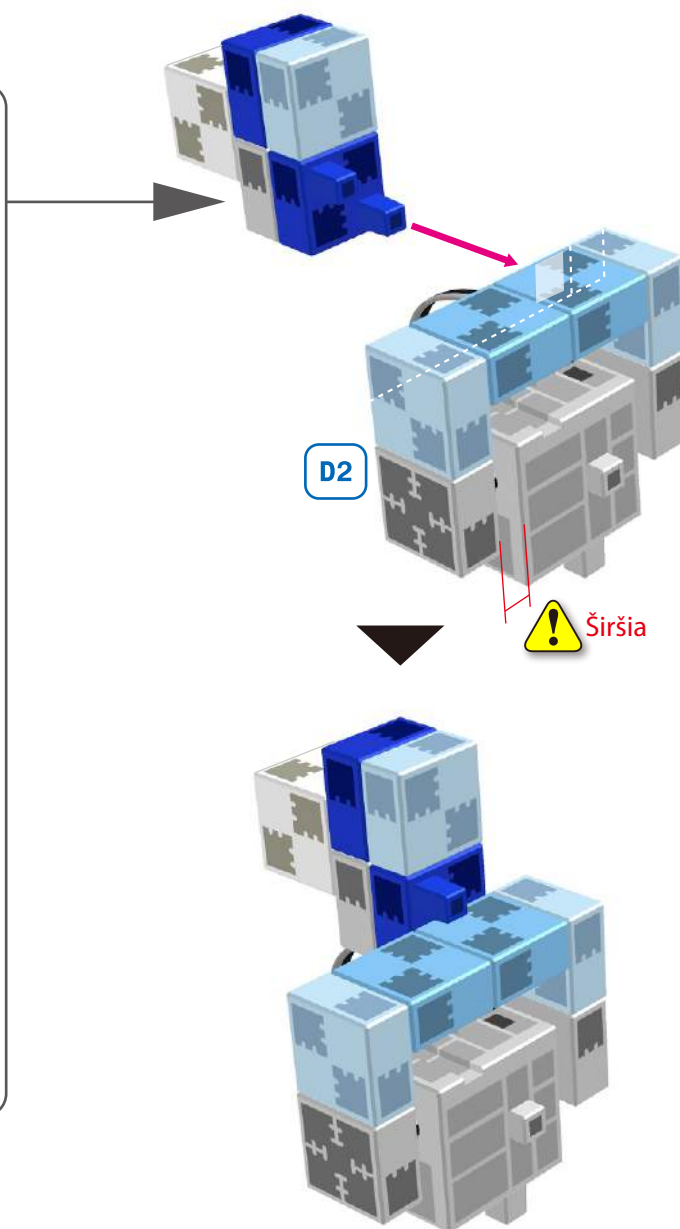
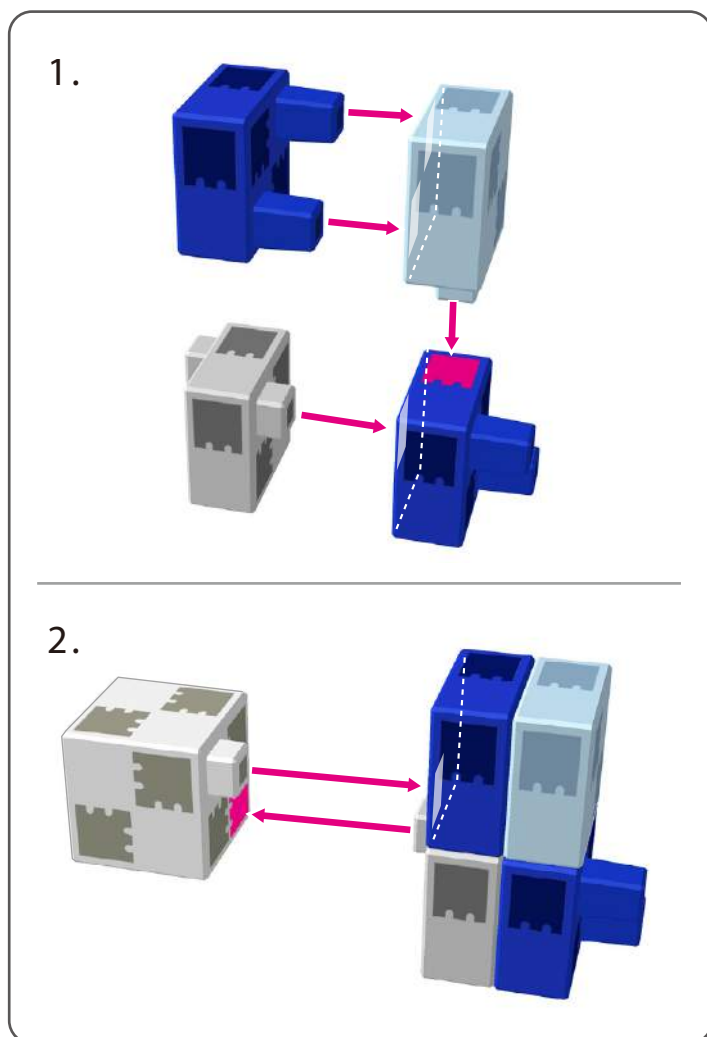

Chodiaci robot

2

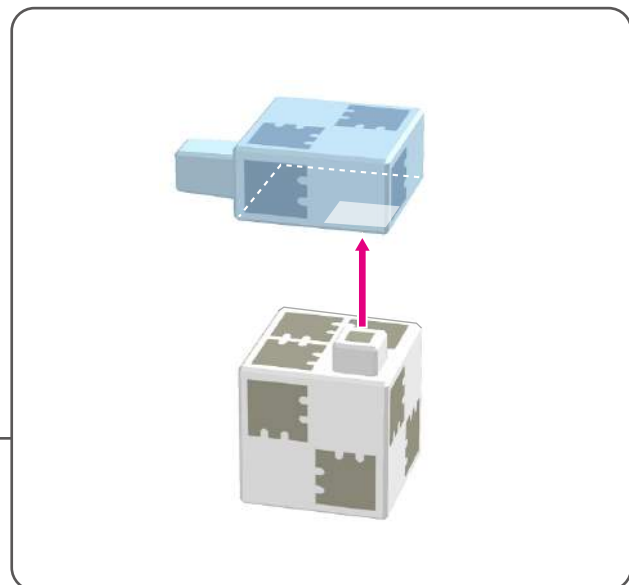
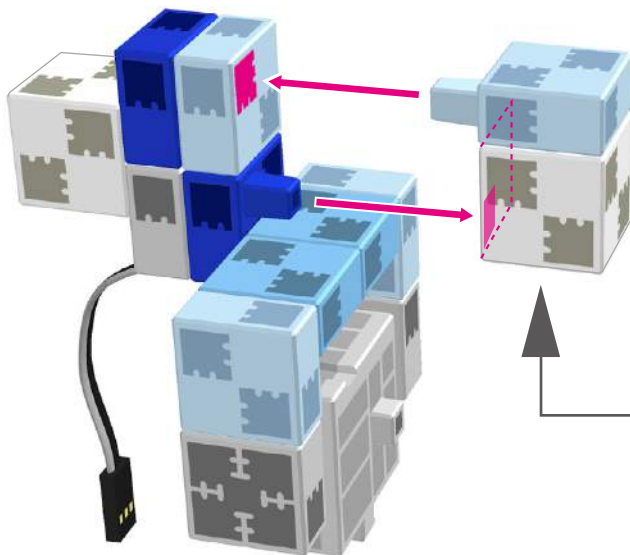

3

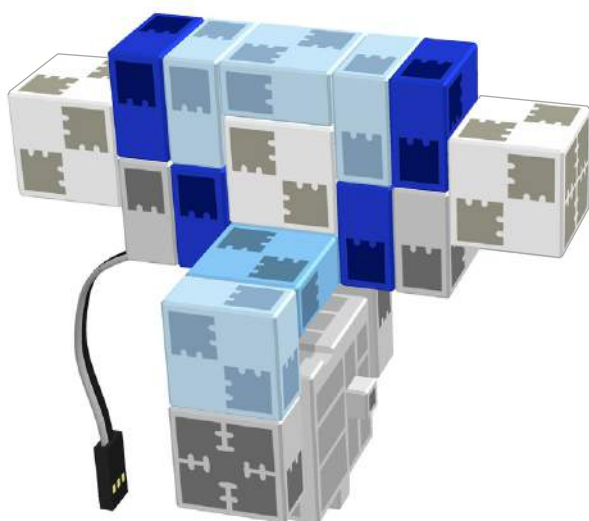
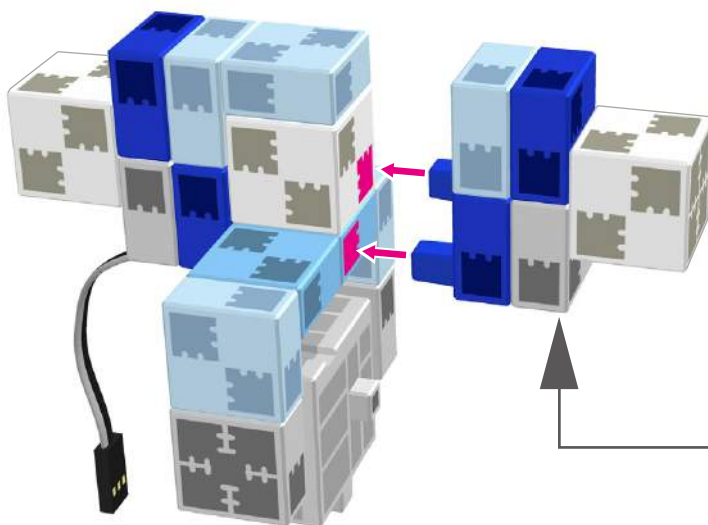

1.

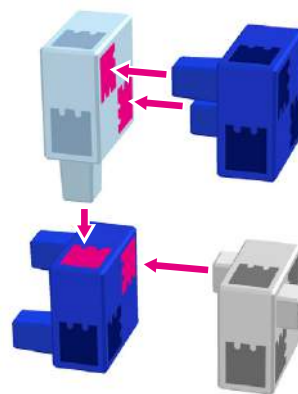

2.

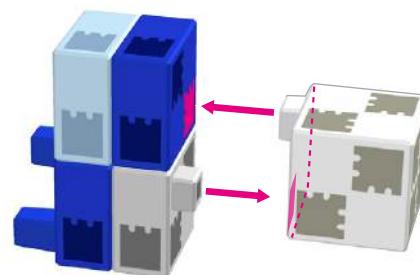

Chodiaci robot

4

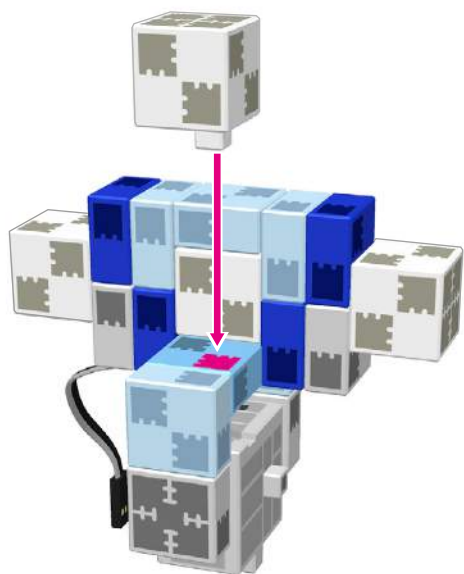

5

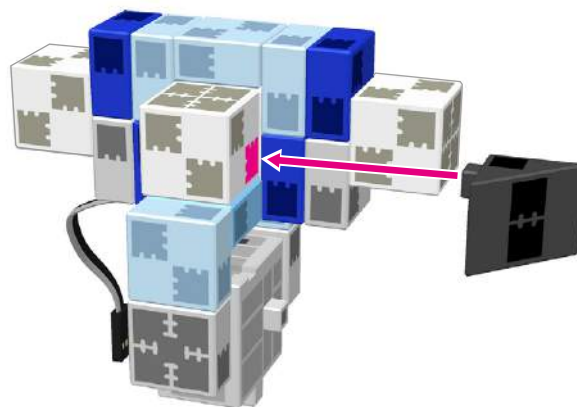

6

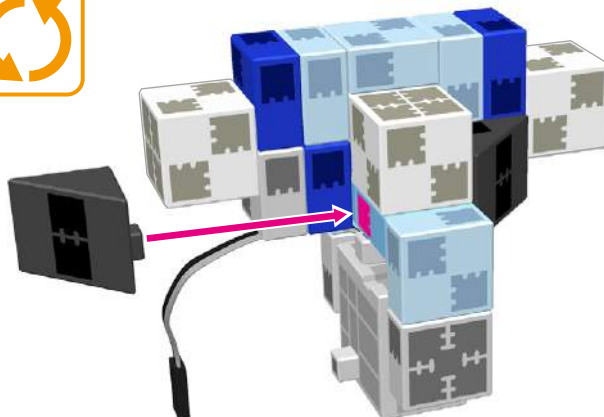

7

Pripojovací kábel ku senzorum



Šedá

Čierna

Zelená



Uistite sa že káble sú zapojené správne!

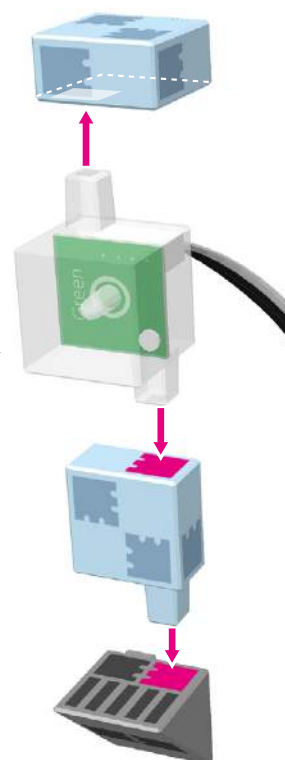

Chodiaci robot

8

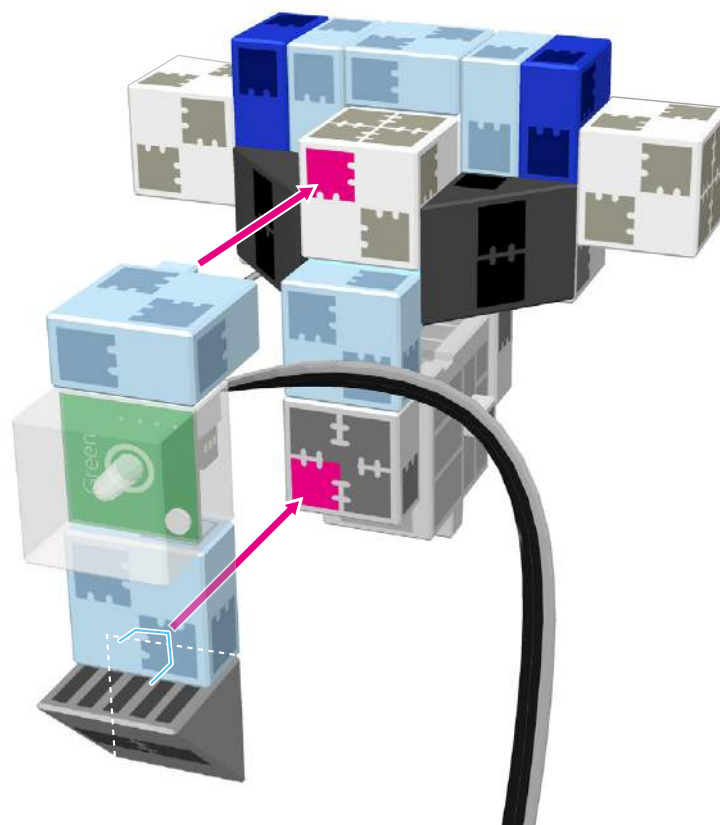

Dokončené torzo

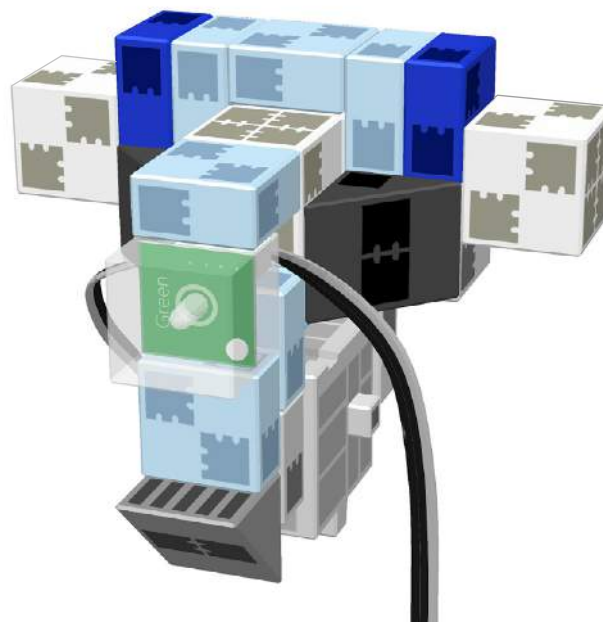

Chodiaci robot

Stavba pravej ruky

D4

× 1

× 2

× 1

× 2

× 2

× 3

× 1

①

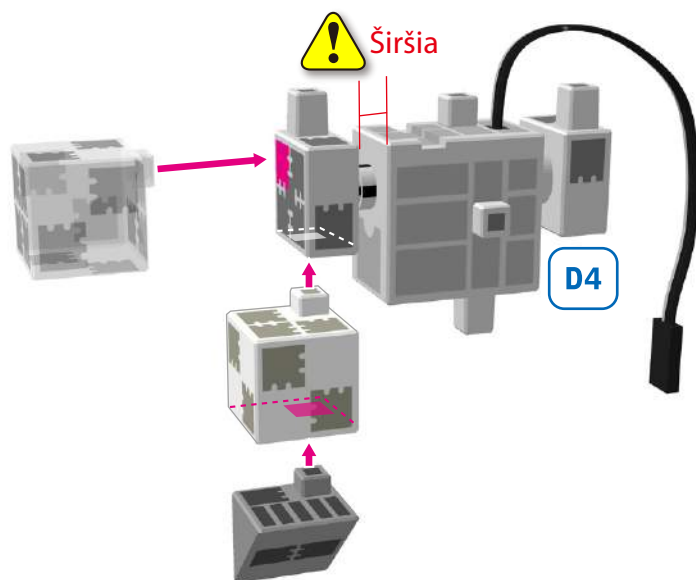

②

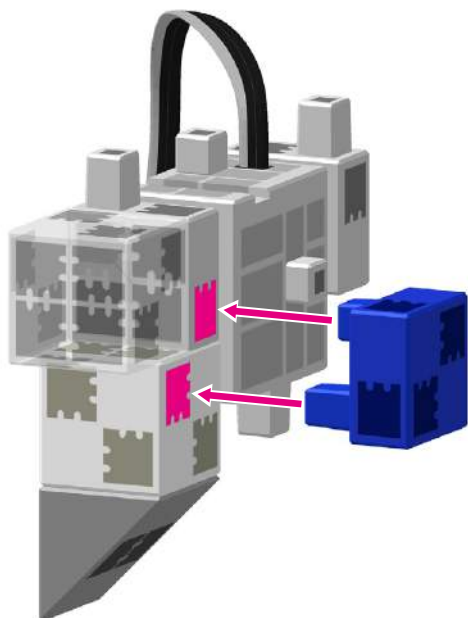

③

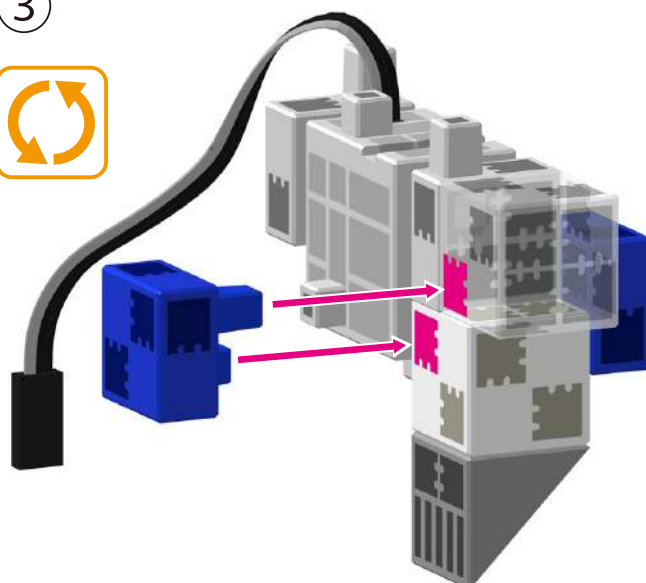

Chodiaci robot

4

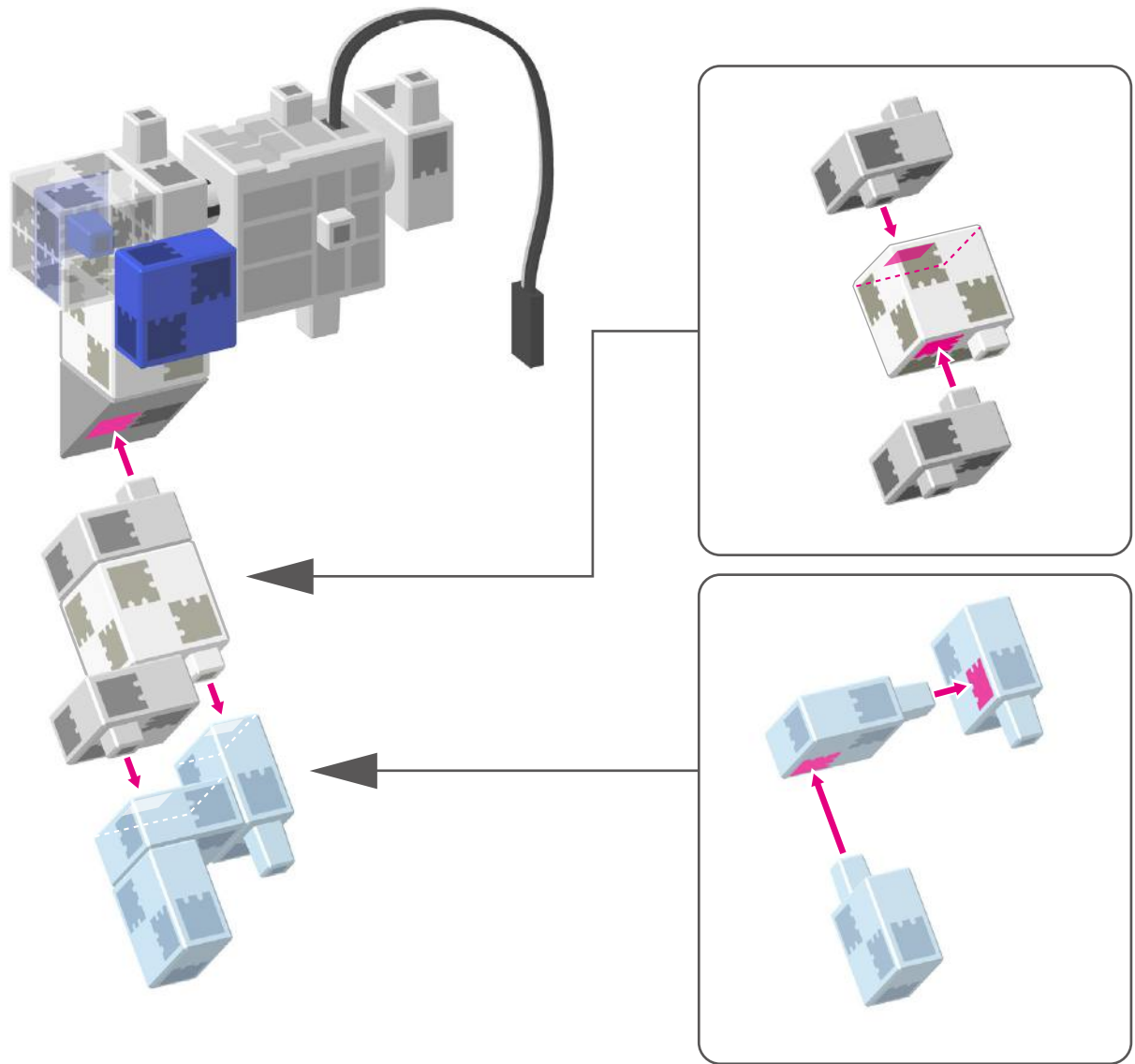

Dokončená pravá ruka

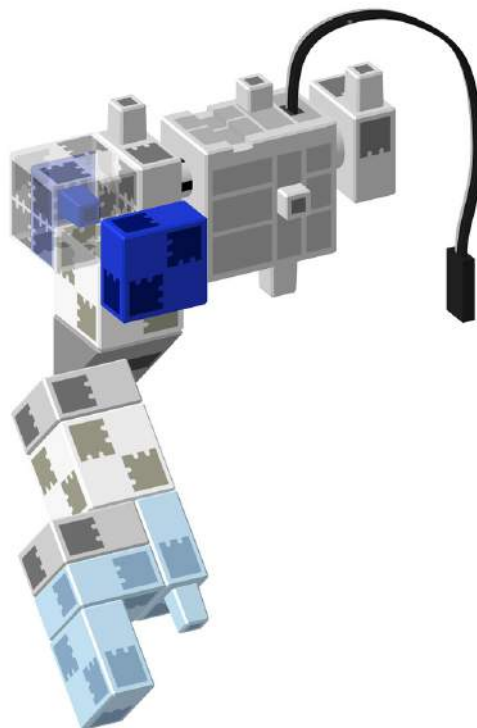

Chodiaci robot

Stavba lavej ruky

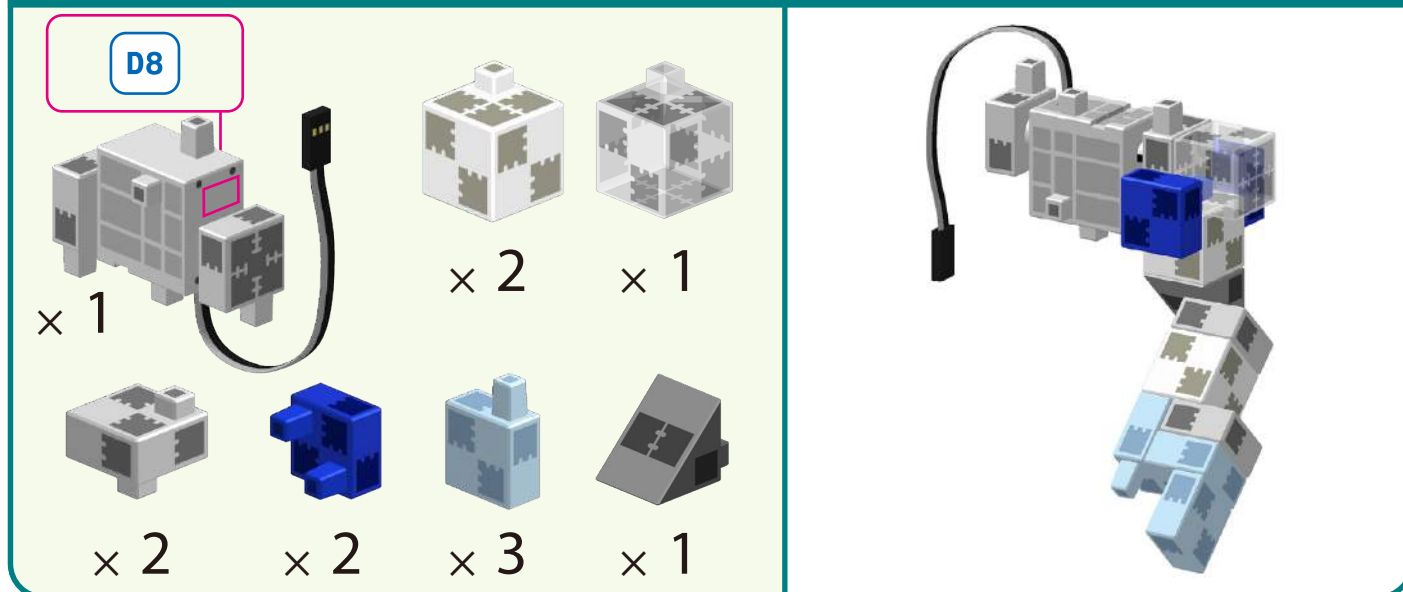

1

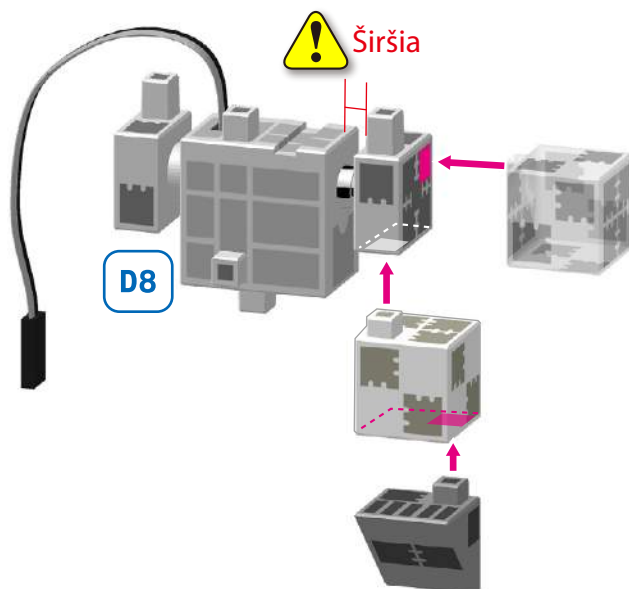

2

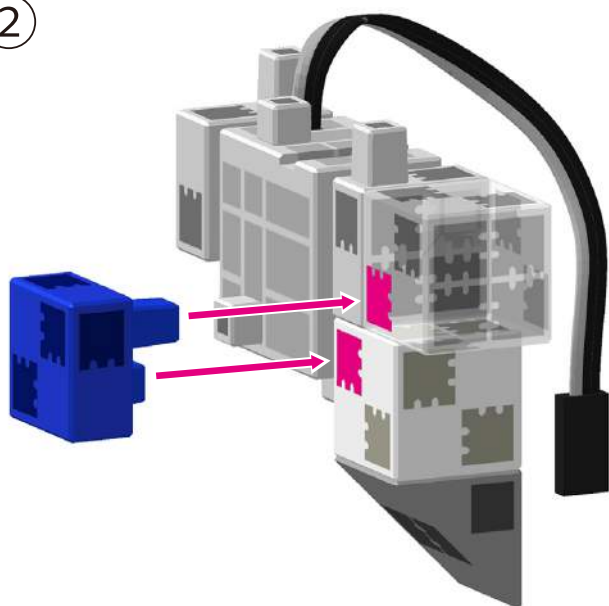

3

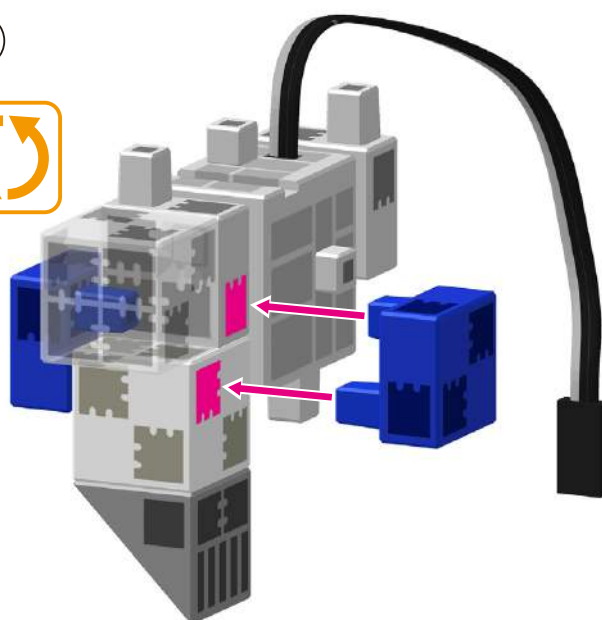

Chodiaci robot

4

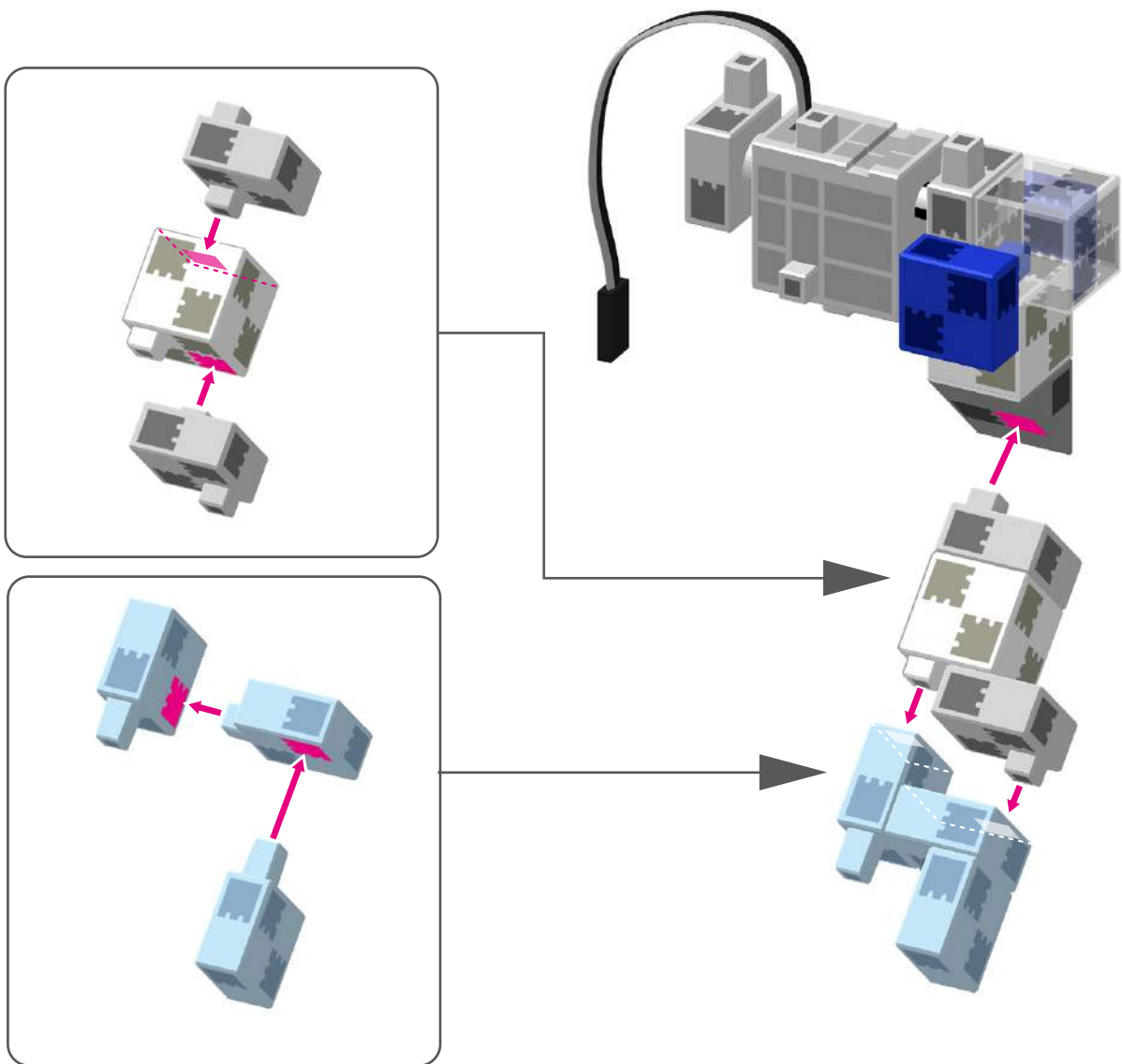

Dokončená ľavá ruka

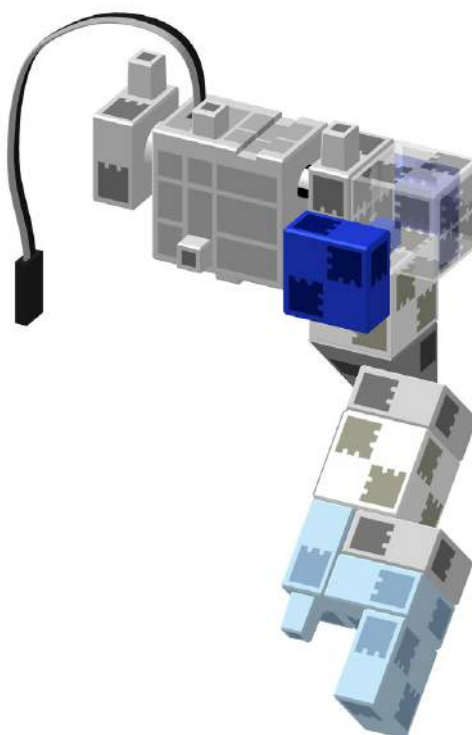

Chodiaci robot

Stavba hlavy

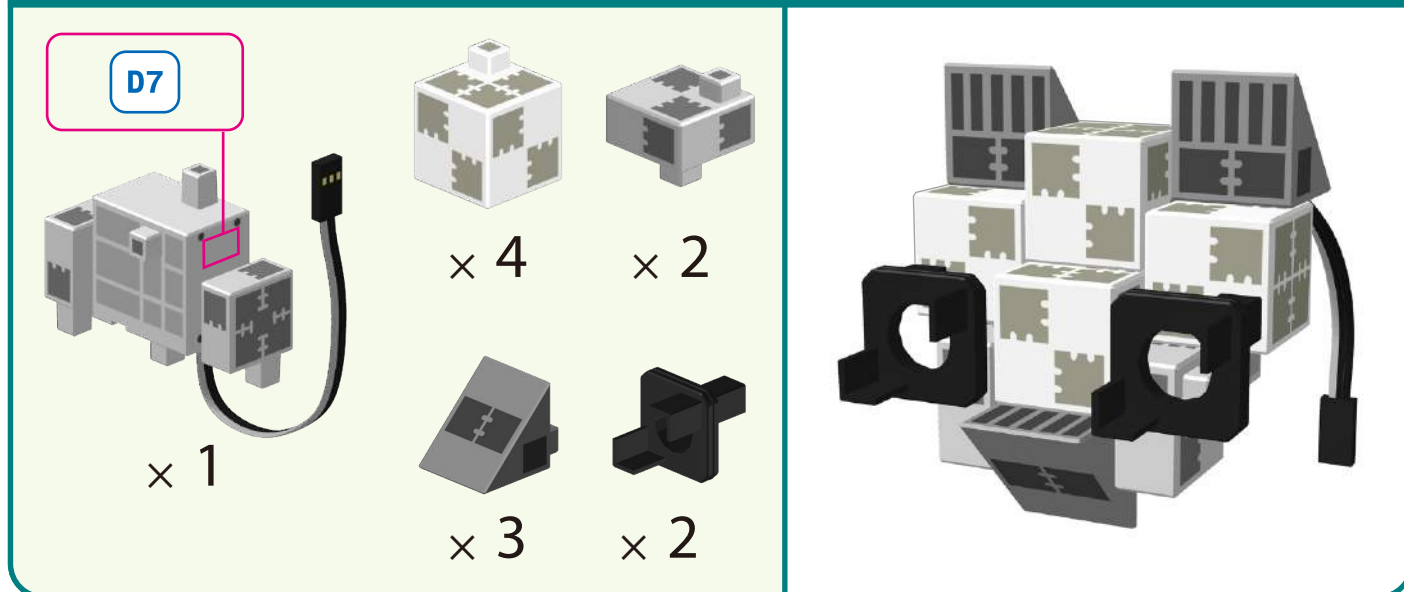

①

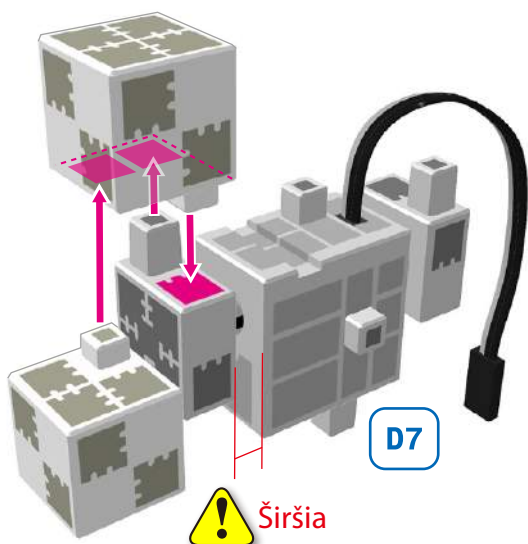

②

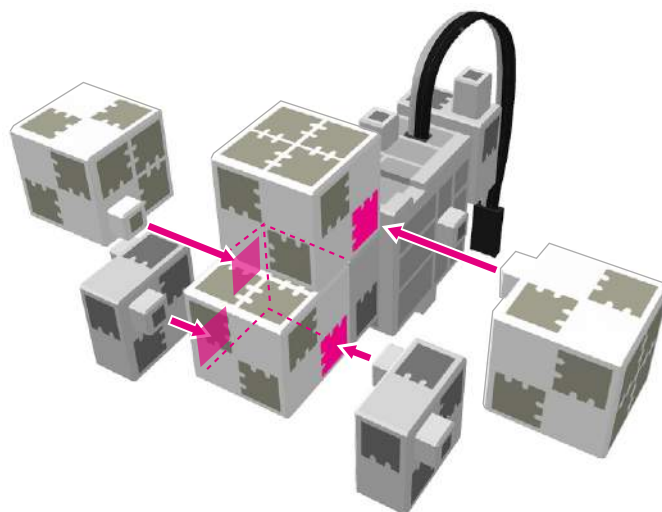

③

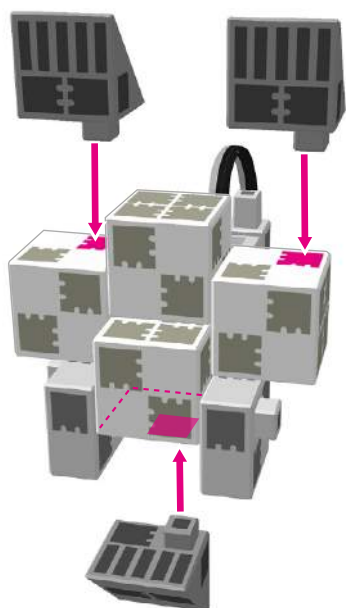

④

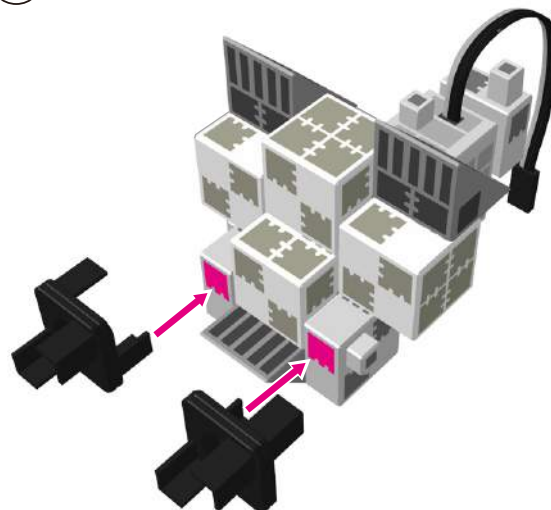

Chodiaci robot

Stavba zadnej časti

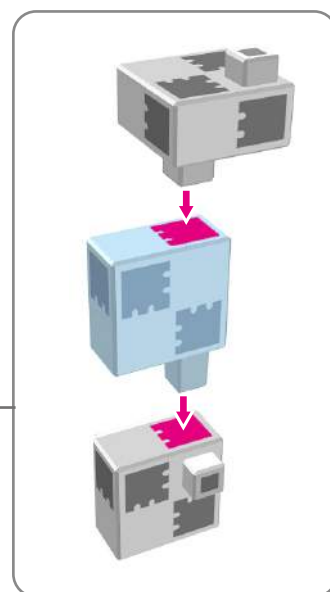
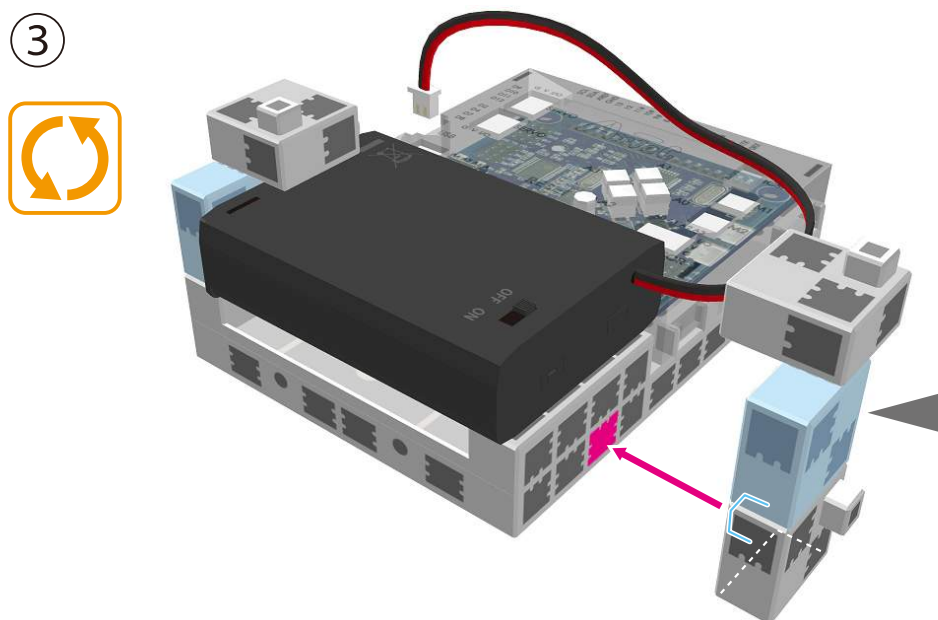
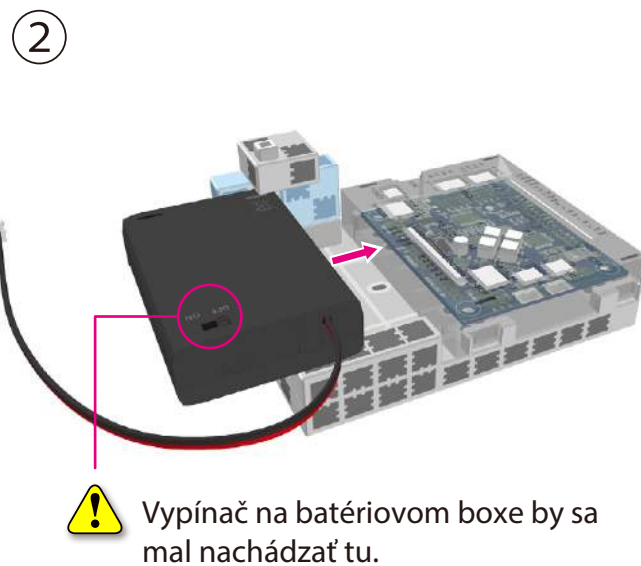
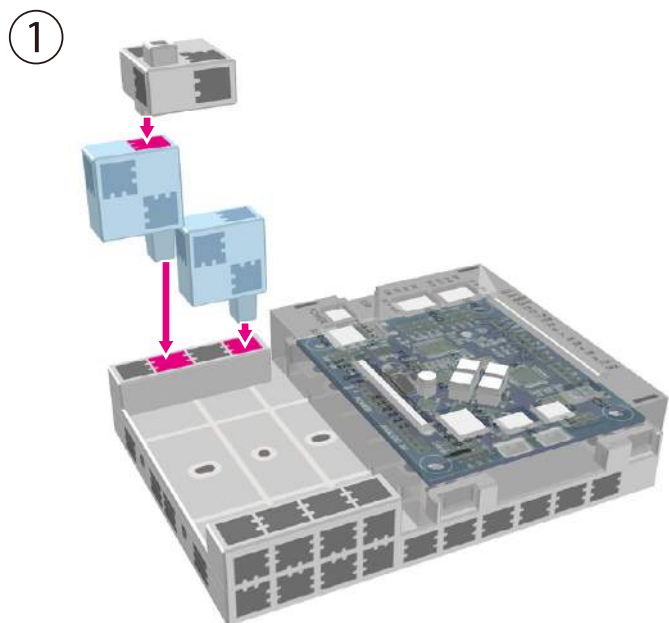
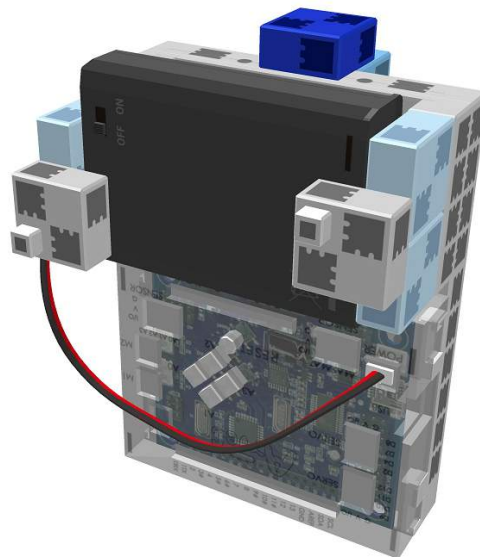
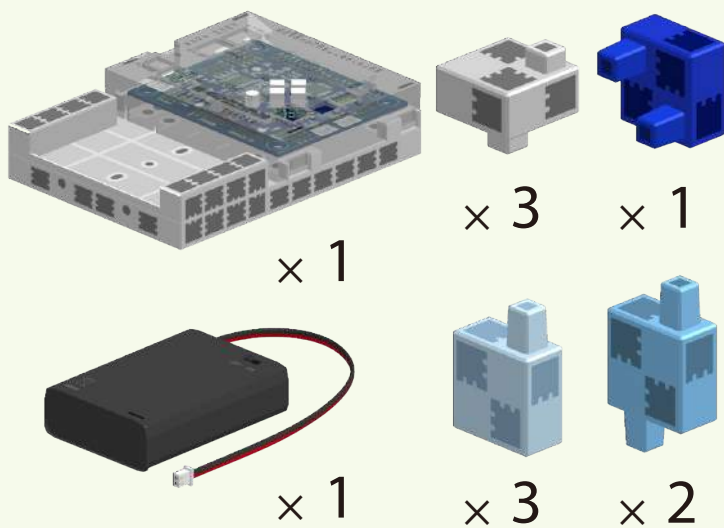

Chodiaci robot

- ④ Connect the cable from the battery box to the **POWER** pins on the board.

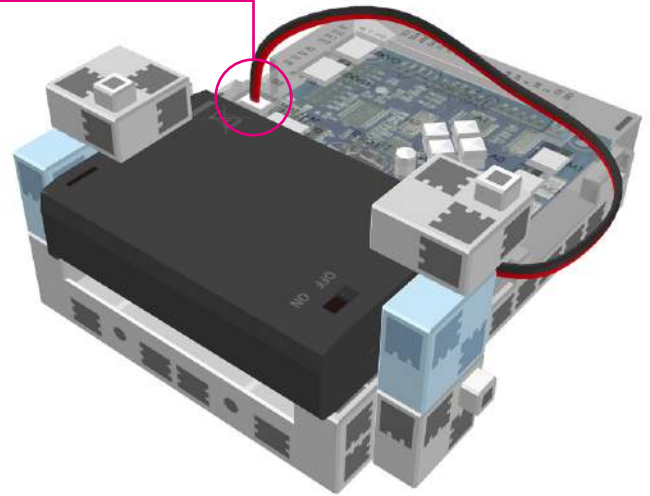
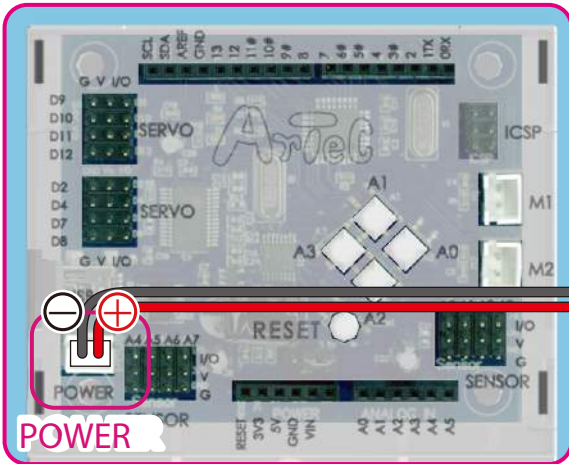

⚠ Make sure the cables are inserted correctly!

- ⑤

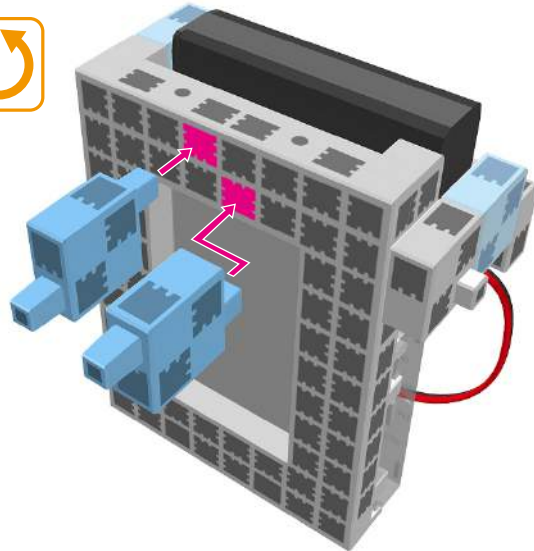

- ⑥

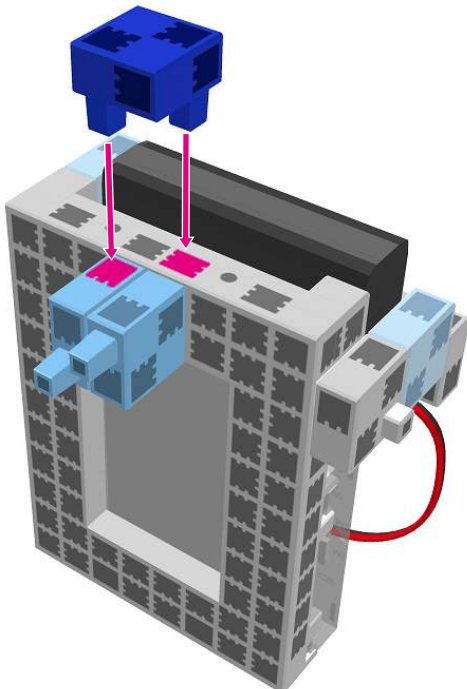

Completed Back

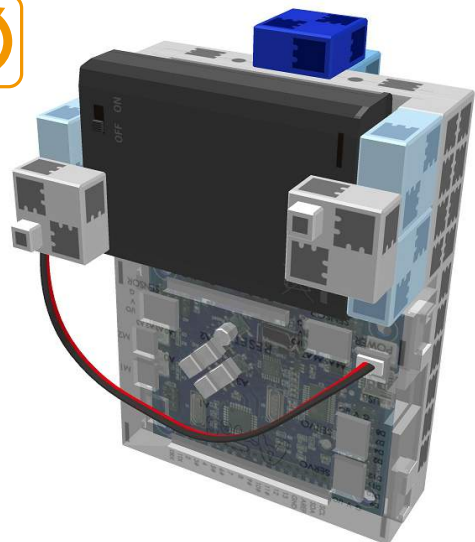

Chodiaci robot

Dokončené telo

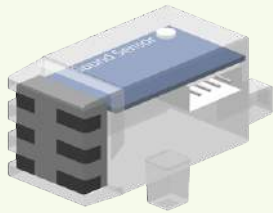

× 1



× 2

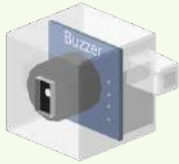

× 1



× 2

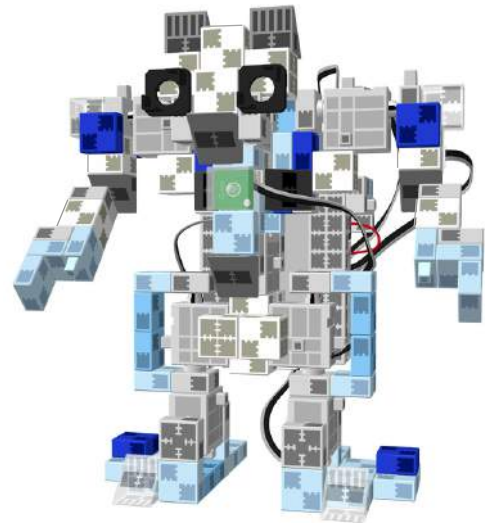

①

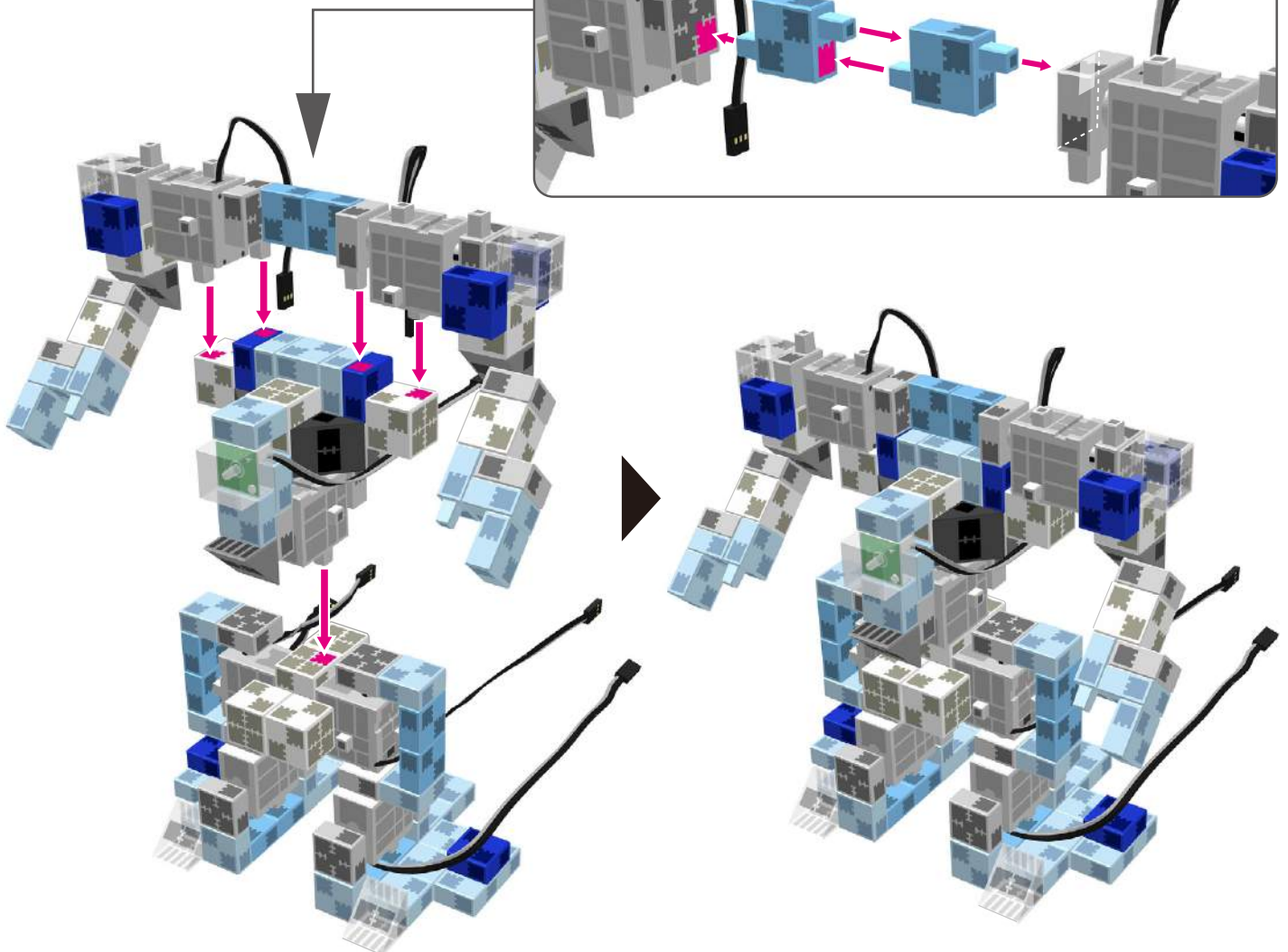
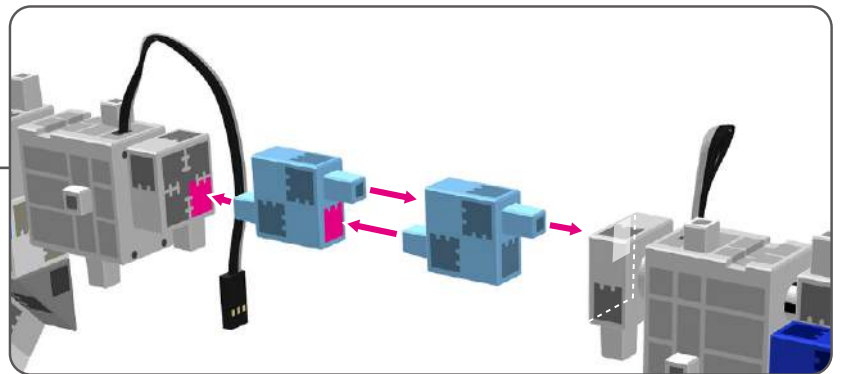

Chodiaci robot

2

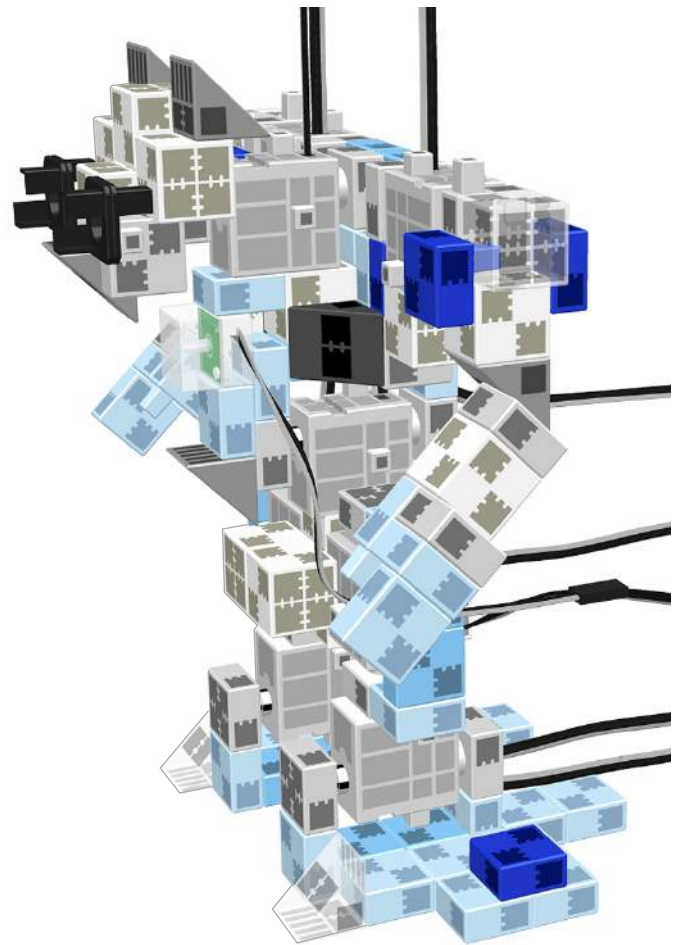
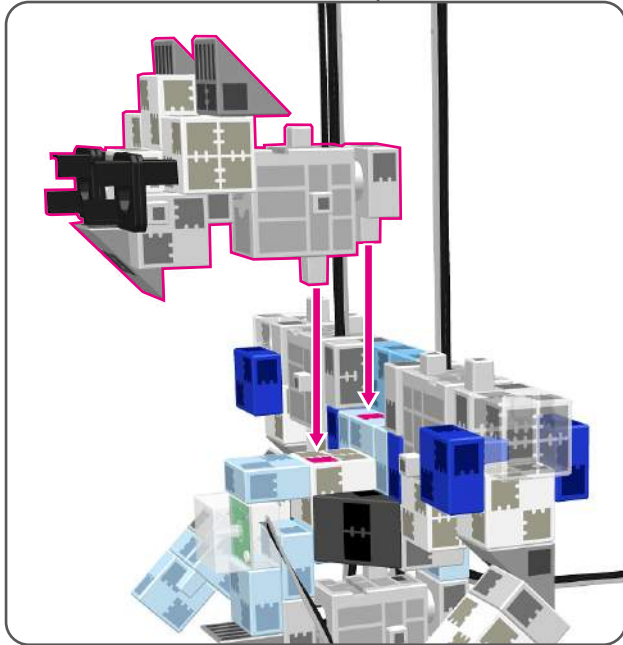

3

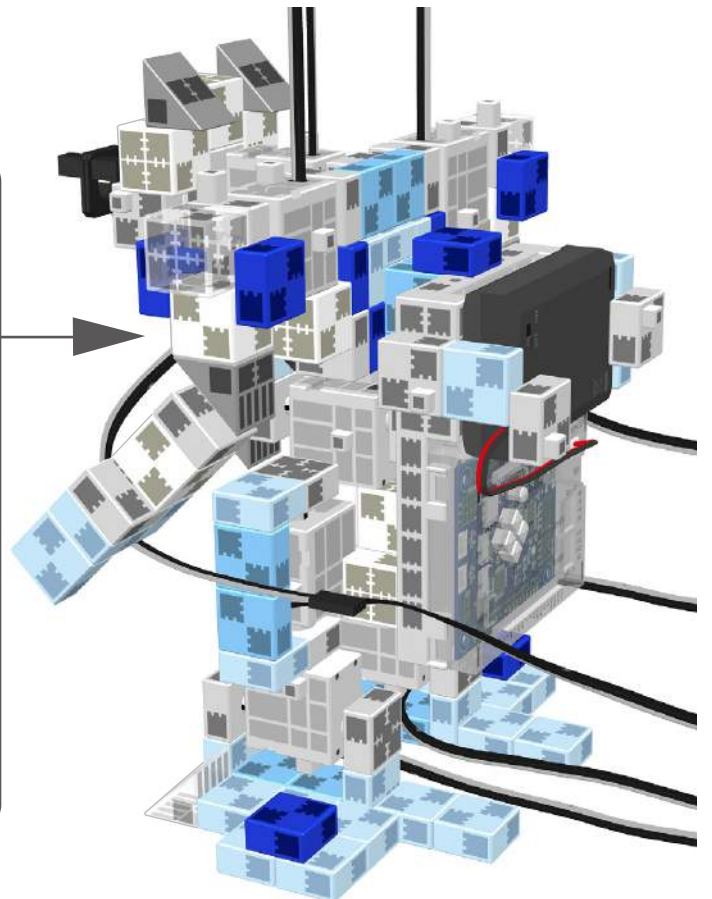
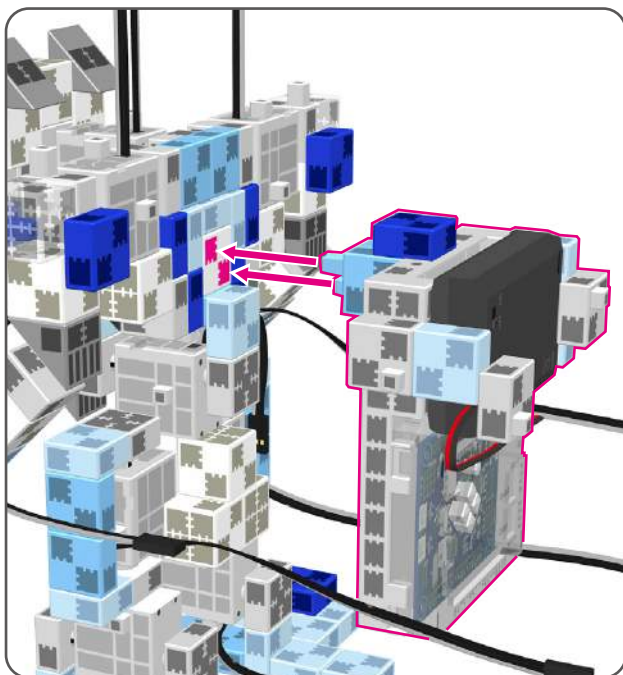

Chodiaci robot

4 Pripojte zvukový senzor A1.

Pripojovací kábel ku senzoru

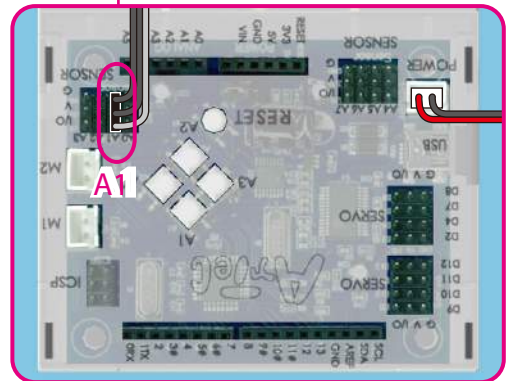
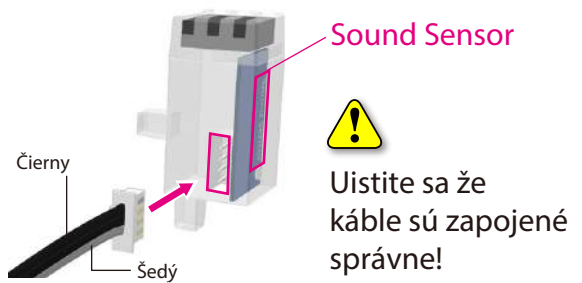
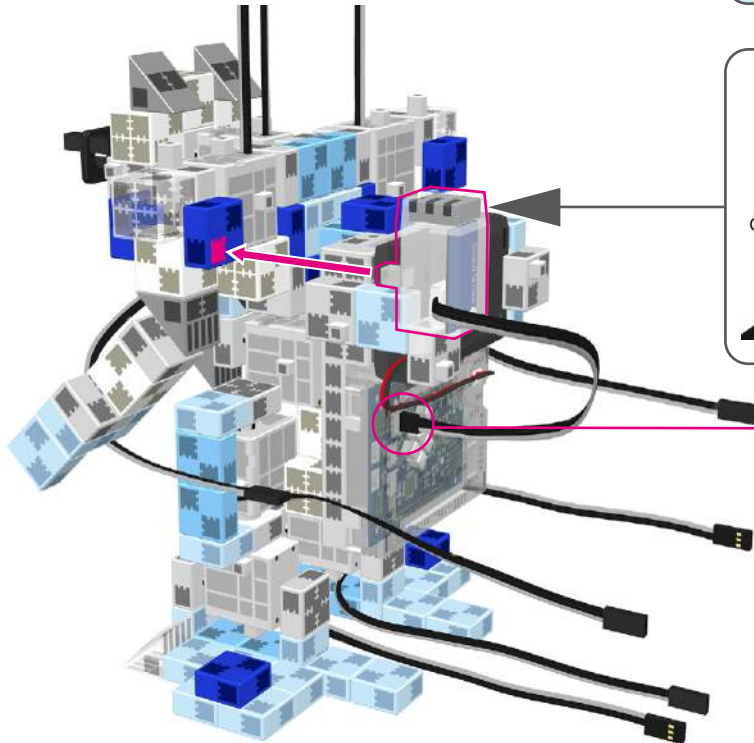
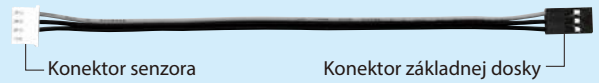

Uistite sa že káble sú zapojené správne!

5 Pripojte Bzučiak do A2.

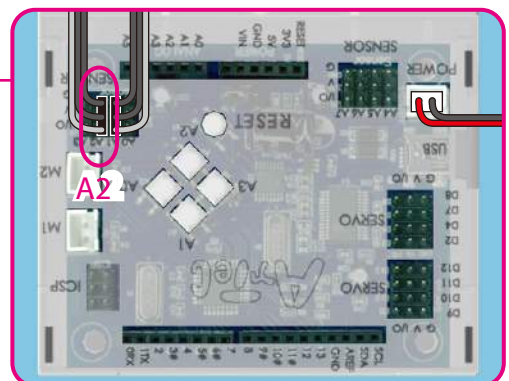
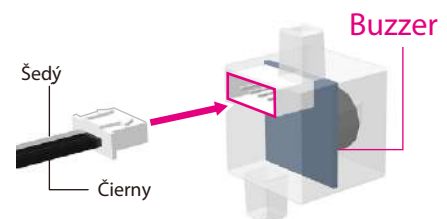
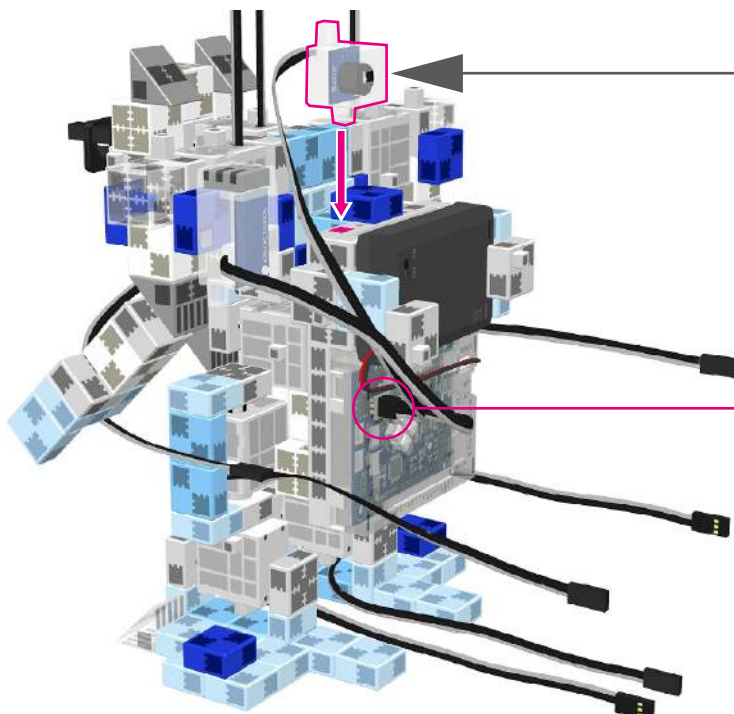

Uistite sa že káble sú zapojené správne!

Chodiaci robot

6 Pripojte LED /zelená/ do A3.

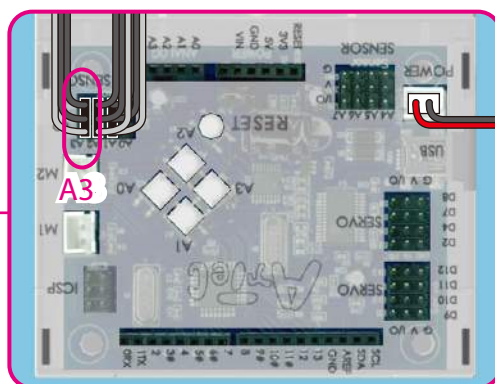
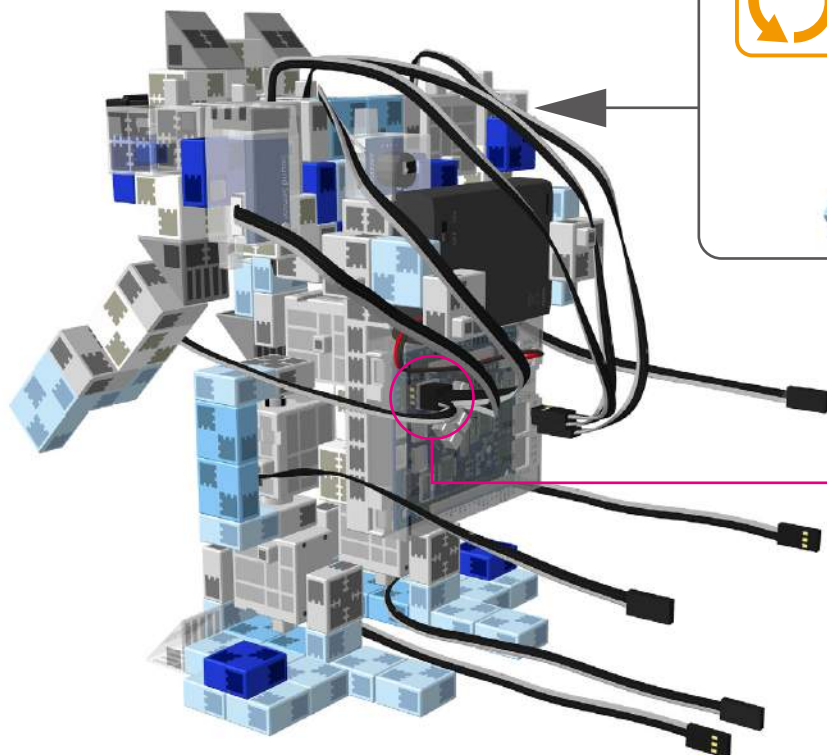

⚠ Uistite sa že káble sú zapojené správne!

7 Pripojte tri servomotory na miesto v základnej doske tak ako je to zobrazené na obrázku.

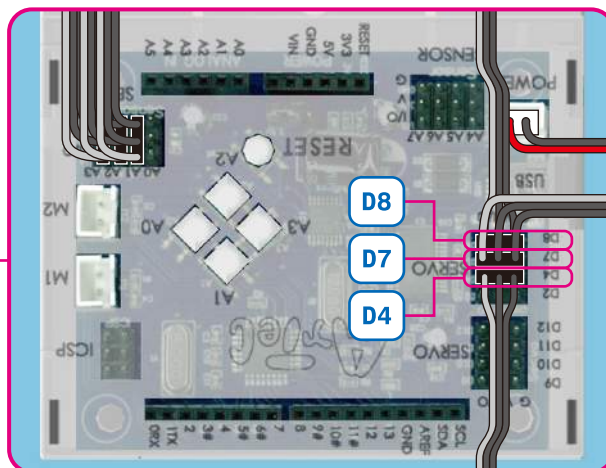
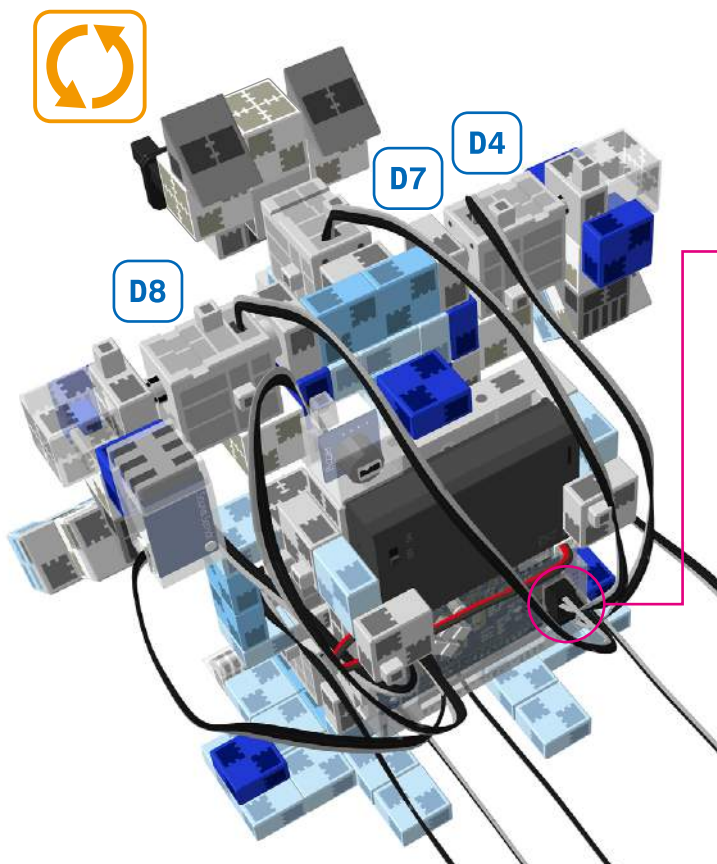

⚠ Uistite sa že káble sú zapojené správne!

Chodiaci robot

- 8 Pripojte dva servomotory na miesto v základnej doske tak ako je to zobrazené na obrázku.

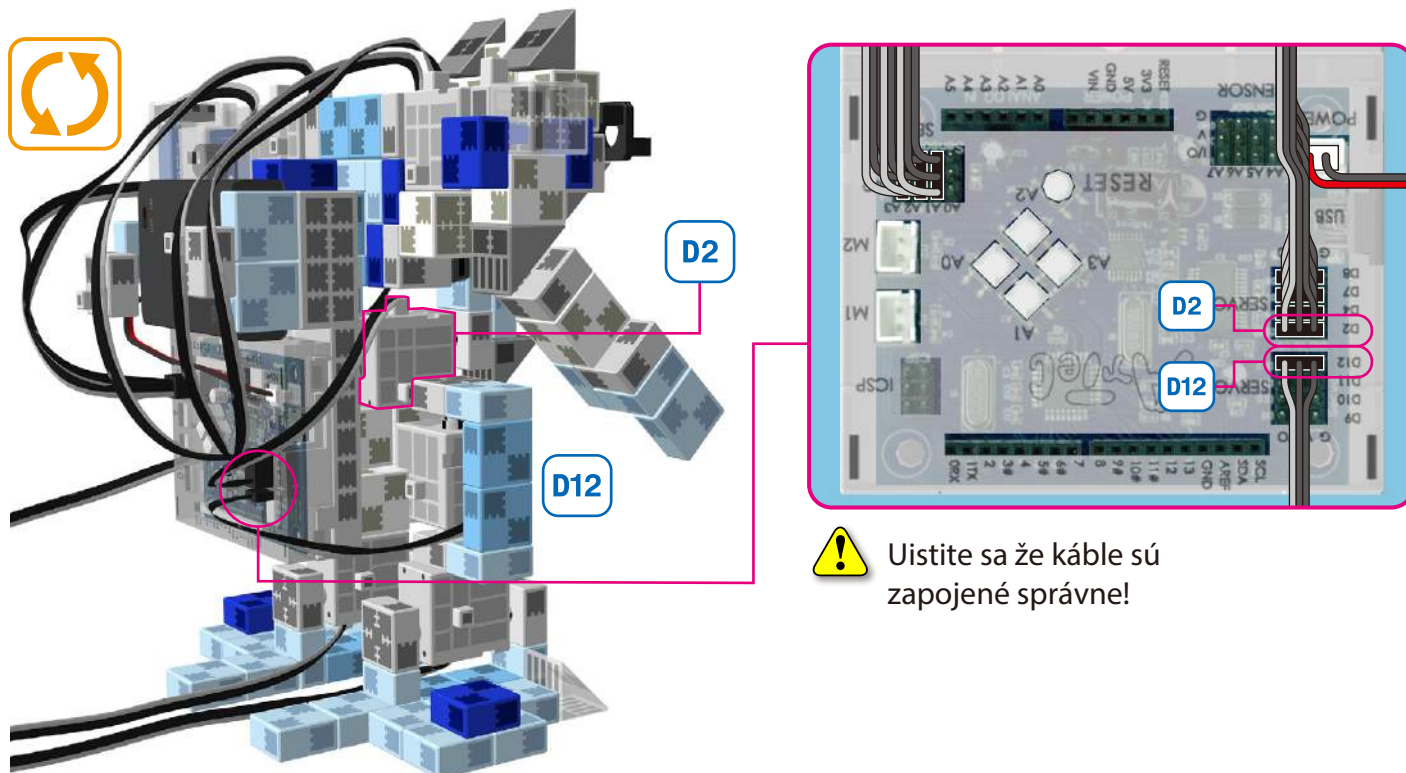

⚠ Uistite sa že káble sú zapojené správne!

- 9 Pripojte dva servomotory na miesto v základnej doske tak ako je to zobrazené na obrázku.

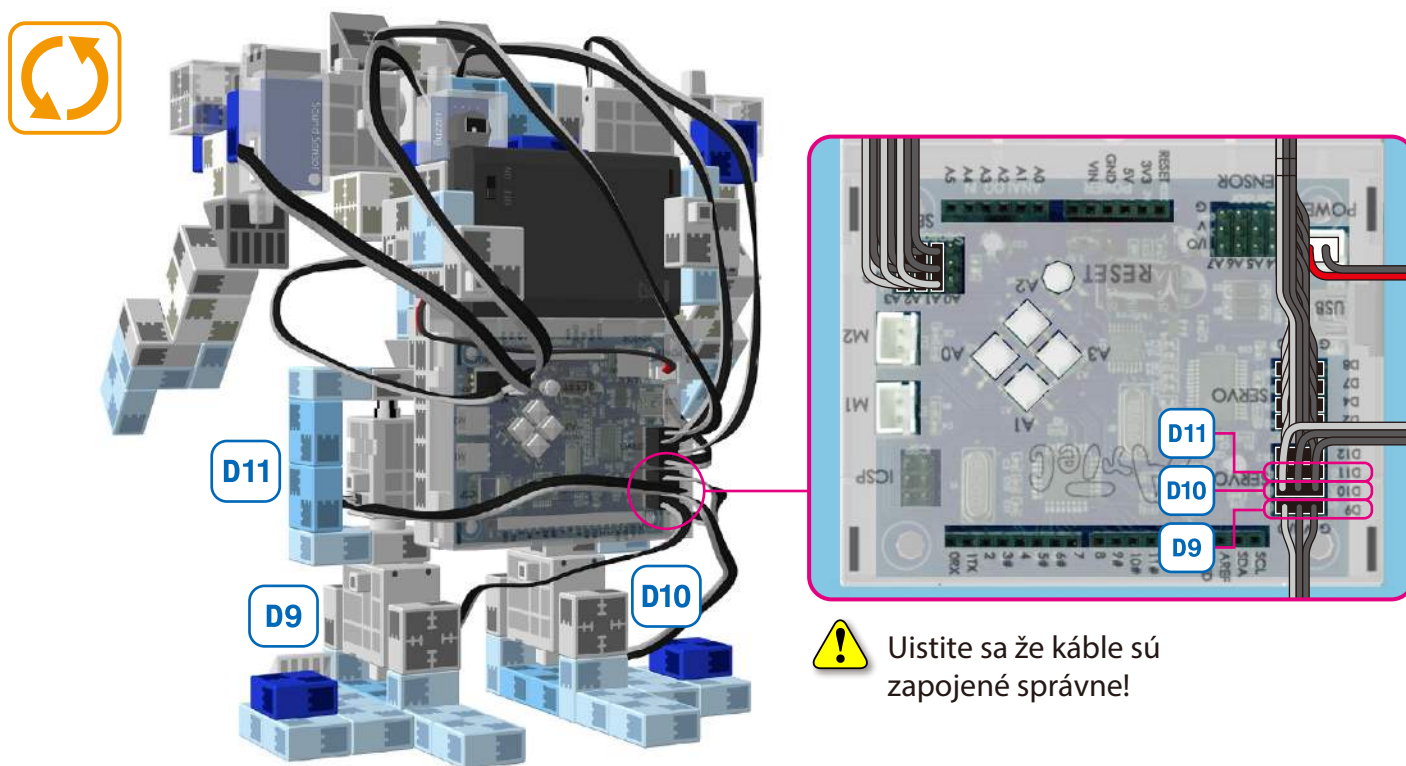

⚠ Uistite sa že káble sú zapojené správne!

Chodiaci robot

Výmena batérií

①

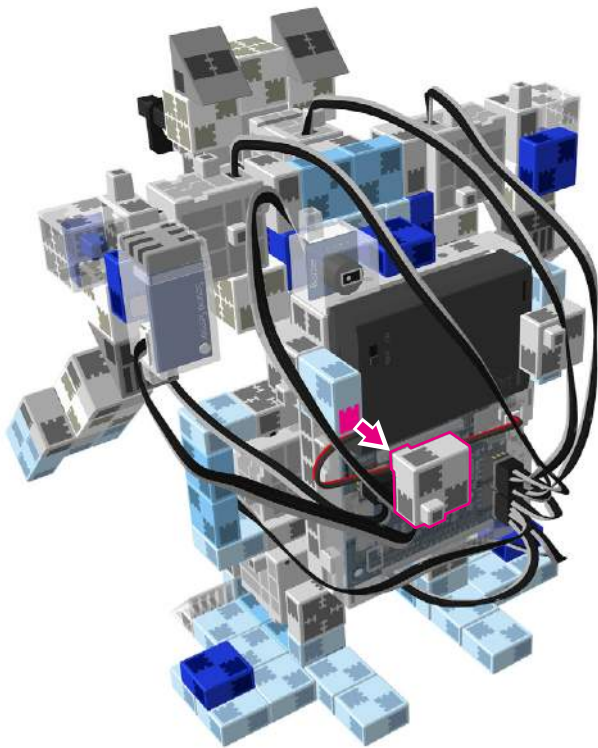

②

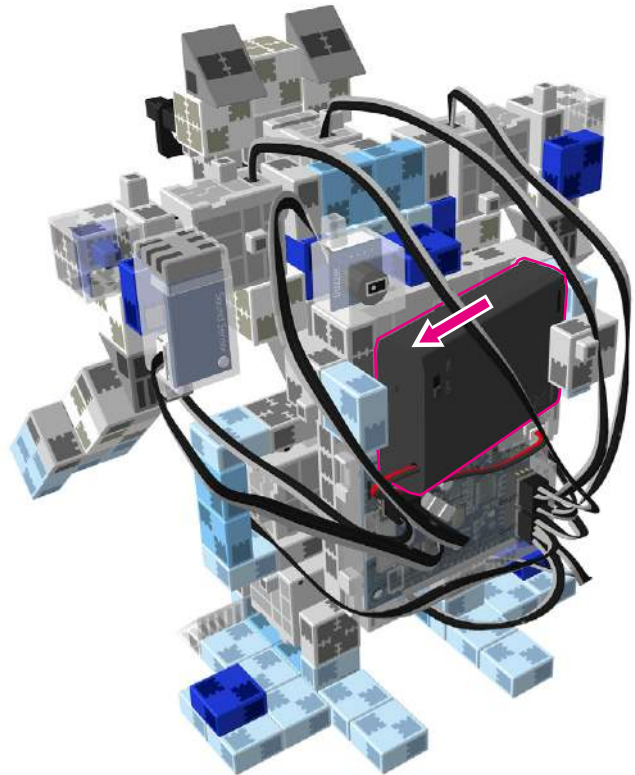

③



④

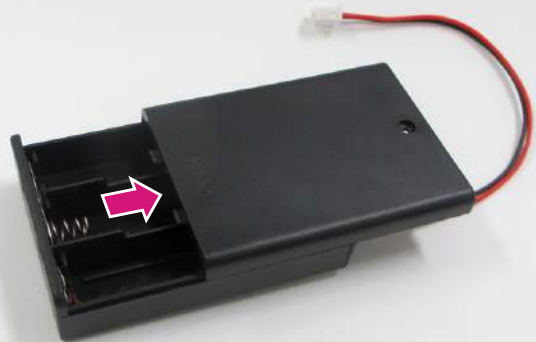

⑤

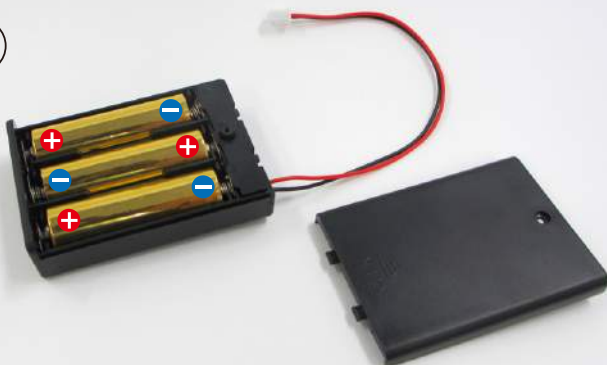

Použite skrutkovač
(Phillips #1) pre otvorenie.



Vložte batérie
(dbajte pri tom na správnu polaritu).

Umiestnite kryt batériového boxu
naspäť na miesto.

Chodiaci robot

Dokončený chodiaci robot



Pred použitím robota sa uistite že ste postupovali podľa návodu a robot je zložený správne.

Predná strana

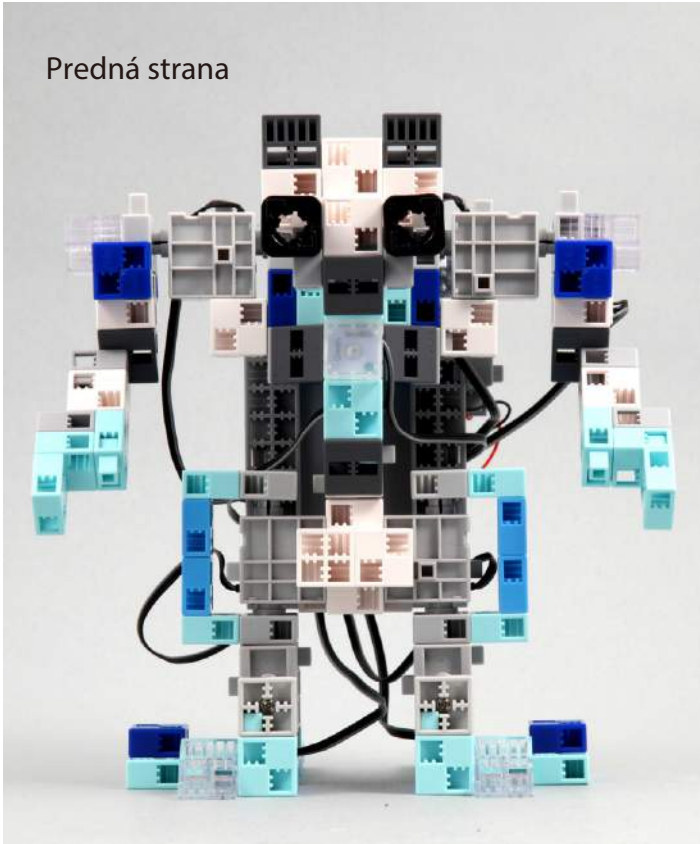

Ľavá strana

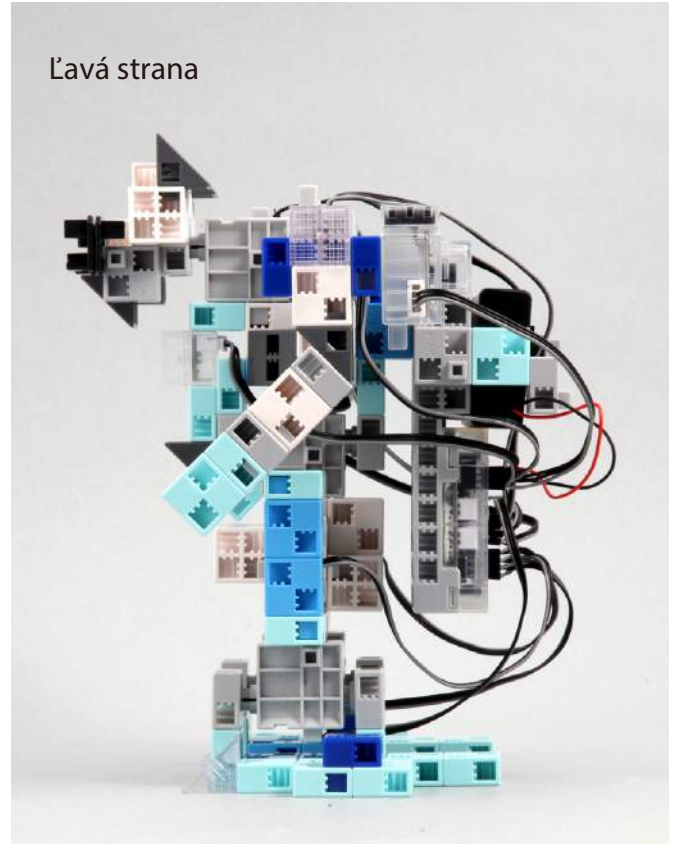

Zadná strana

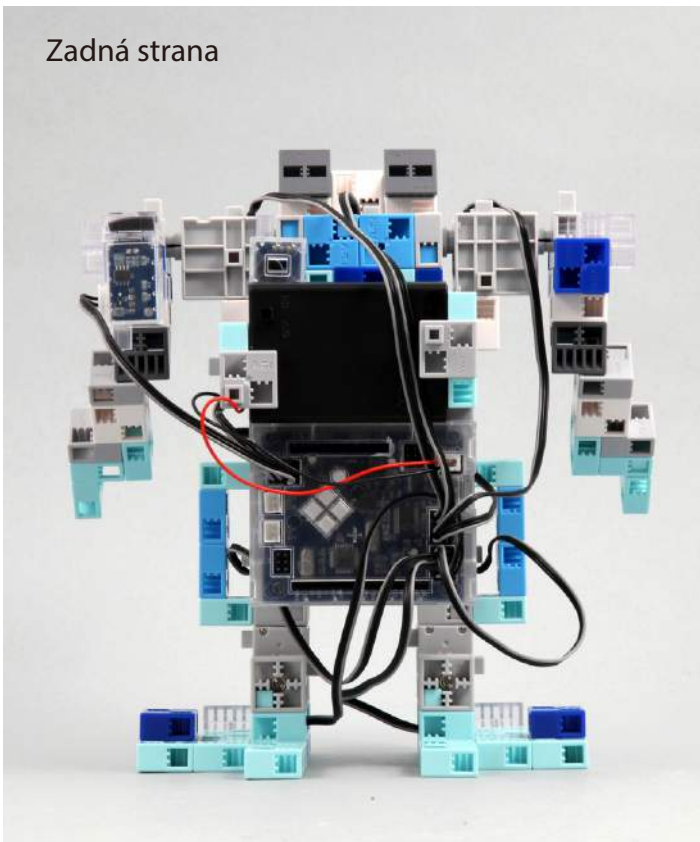

Pravá strana

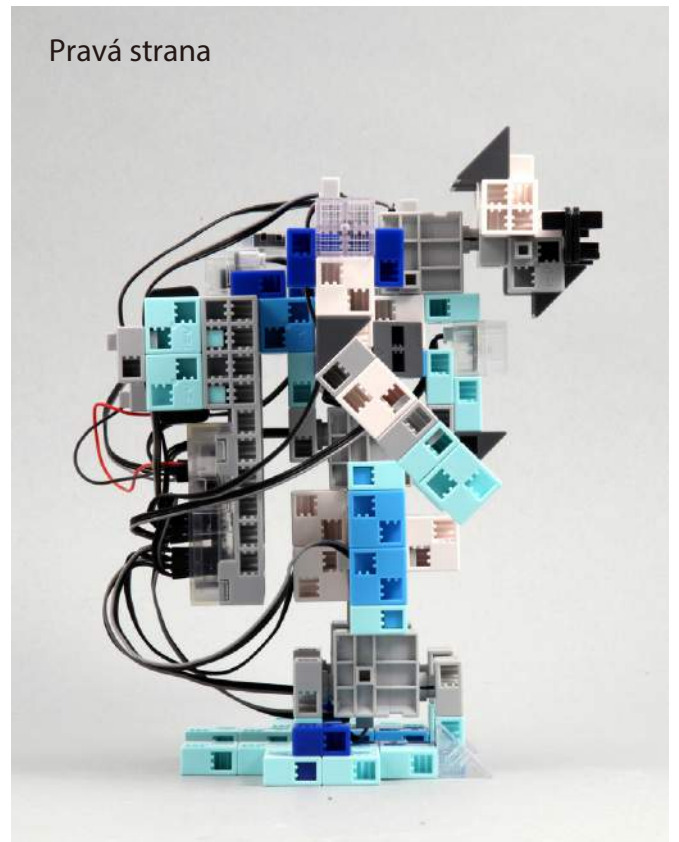

Chodiaci robot

Ovládanie chodiaceho robota

Nainštalujte softvér umiestnení na stránke:

Po inštalácii softvéru pokračujte na krok 1

<http://www.artec-kk.co.jp/studuino/>

- 1 Pripojte kábel USB k počítaču a základnej doske Studuino.
Pozrite časť 1.3 Studuino programovací manuál pre viac detailov.
- 2 Stiahnite si program pre Vášho robota /BipedWalkingRobot.ipd/ zo stránky www.artec-kk.co.jp/studuino alebo na stránke www.skola.sk/robotika v časti návody na stavbu.

<http://www.artec-kk.co.jp/robotist/>



- 3 Otvorte stiahnutý program.

- 4 Preneste program do základnej dosky Studuino pomocou tlačidla prenosu /transfer Button/



- 5 Odpojte USB kábel od základnej dosky Studuino.

Chodiaci robot

Ovládanie tancujúceho robota

- 6 Zapnite vypínač na batériovom boxe a Váš robot začne fungovať.

! Vypnite robota hneď ako zistíte že nevykonáva pohyb presne ako je uvedené nižšie!
V opačnom prípade môže dôjsť k poškodeniu servomotorov.

! Ak sa Váš robot nepohybuje, je pravdepodobné že servomotory sú zapojené nesprávne
alebo diely stavebnice blokujú pohyb. Znovu si prečítajte návod aby ste sa uistili že Váš
robot je zložený správne.

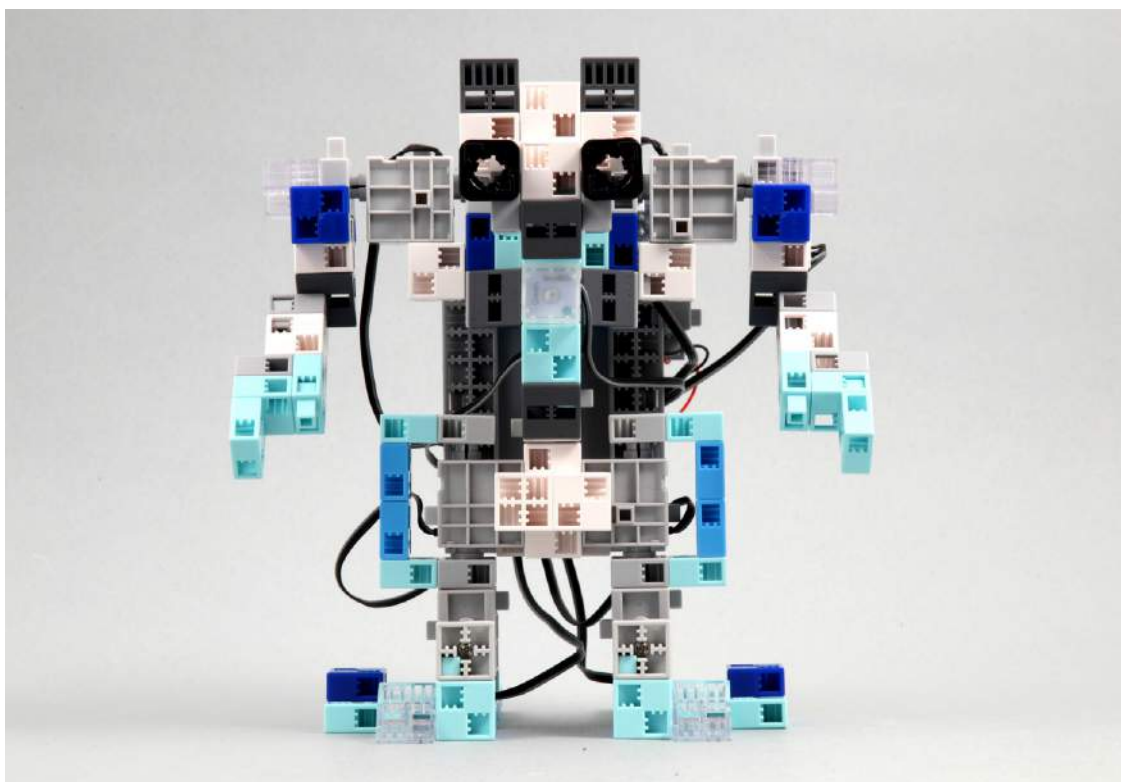

- 7 Po ukončení štartovacej sekvencie (zdvihne pravú ruku), Váš robot začne automaticky kráčať keď zaznamená zvuk.

Chodiaci robot

Kalibrácia senzorov

Niektoré senzory nemusia pracovať správne pri prvom použití a je možné že ich bude treba nakalibrovať.

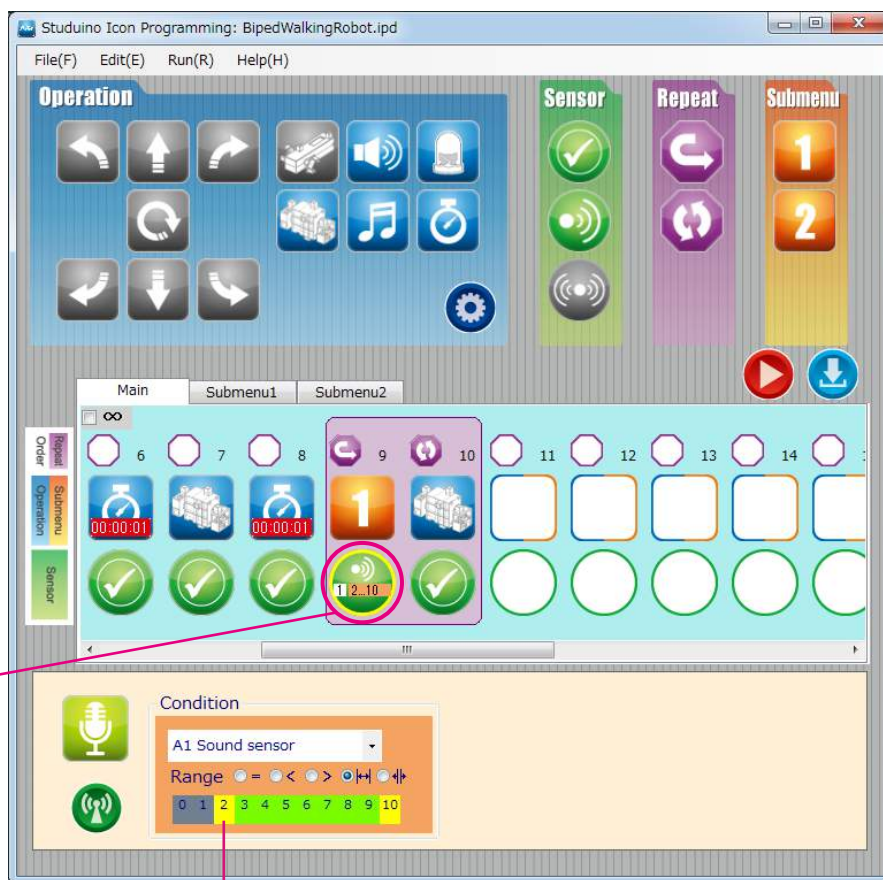

Kliknite na konkrétny senzor a uvidíte tabuľku s hodnotou rozsahu senzora.

Potiahnutím myši doľava alebo doprava nastavíte hodnotu senzora.