

Polytechnika

Príklad vybavenia:

- Laser na popis a gravírovanie dreva a plastov
- Lis a nahrievacia pec na tvarovanie plošných, tvarových, ohýbaných dielcov
- Rezačka polystyrénu pomocou nahrievaného drôtu
- CNC obrábacie centrum
- Formátovacia píla
- Obrábacie stroje
- Simulátory reálnych procesov v polytechnike
- Inštalatérske simulátory

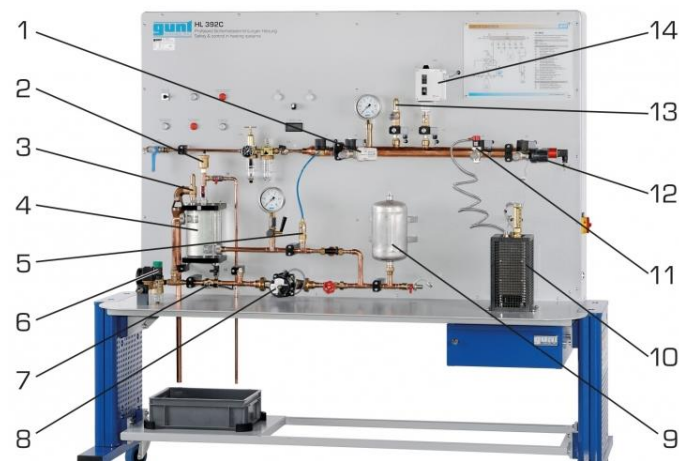
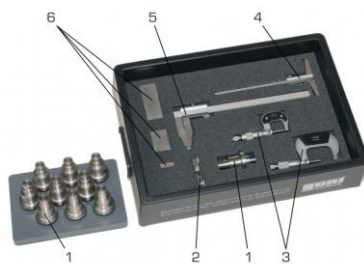
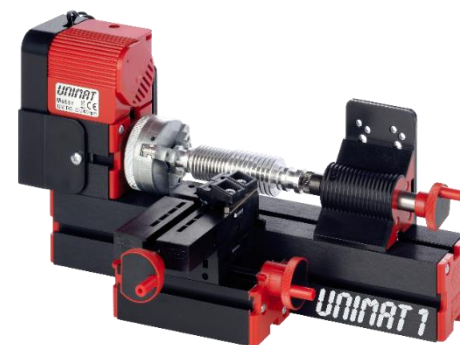

Viac informácií na: [CNC a obrábacie výučbové stroje](#)
[Komerčné CNC frézy a sústruhy](#)
[Simulátory reálnych procesov](#)
[Simulátory manipulačnej techniky](#)

3920 M polytechnika

Učebňa metrológie a metalografie



PT102 metrológia set I-2



PT103 metrológia set I-3



PT106 metrológia set I-6

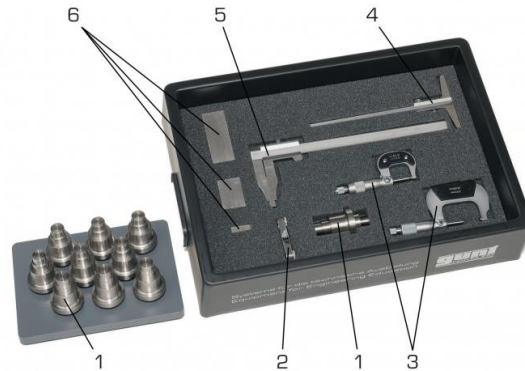

PT105 metrológia set I-5

- 1 test piece
- 2 radius gauges
- 3 external micrometer
- 4 depth caliper gauge
- 5 caliper gauge
- 6 block gauge



PT201 metrológia set II-1

Učebňa elektrotechnických meraní a automatizácie

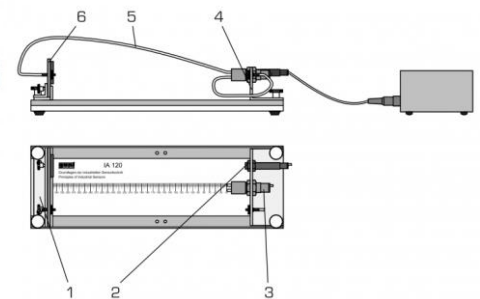
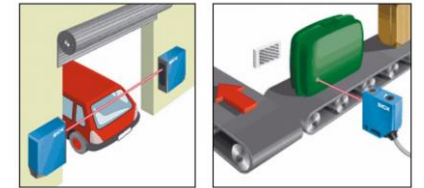

IA120 princíp fungovania priemyselných senzorov

- 1 slide
- 2 reflex photoelectric barrier
- 3 light guide
- 4 sensor holder (interchangeable)
- 5 fibre-optic cable
- 6 reflector holder